

Stepping System catalogue V3.0



- AC servo
- Stepping drive motor
- Induction asynchronous servo
- Linear motor drive
- Industry-specific servo
- Control product integration customization

Serving customers and adding value to customers

Company Profile

Hangzhou Bergerda Automation Technology Co., Ltd. is located in a beautiful paradise on earth - Hangzhou, China. It is a high-tech enterprise that provides global customers with servo, stepping, frequency conversion, brushless motor drive control products, and industrial drive control solutions. Excellence in product development, efficient and high-quality production, enthusiastic and caring service. Always take the customer's needs as its responsibility.

Bergerda's motor control products include AC servo drives and servo motors, stepping drives and stepping motors, inductive asynchronous servo drives and motors, Brushless motor and drive, and custom control solutions for all types of industries. Widely used in textile packaging, CNC machine tools, printing, embroidery, sculpture, advertising, laser, electronics and other automated machinery. At present, there are twelve types of stepping systems, including B D E F four series, nearly 30 kinds of specifications servo systems, NS digital series and LS closed loop series. S series induction asynchronous servo, Brushless motor and drive (B L D C), T-series CNC turret-dedicated servos and P-series plastic machinery-specific servos and so on which include control and control integrated industrial solutions. We have become a professional company with a complete product line in Chinese motion control industry. Perfect pre-sale, sales, after-sales service, from customer design machine selection, equipment debugging, post-maintenance, always with patience, enthusiasm, professional service to return customers.

The company fully implements the concept of "professional, quality, and service". With high-tech products, excellent quality, and high-quality services, customers can be assured of their ease of use, adding value to customers and realizing the long-term development of the company.

Based in the domestic market, Bergerda has established sales and service networks in Zhejiang, Jiangsu, Guangdong, Fujian, Shandong, Hunan and Guangxi. In foreign markets, products are exported to the United States, Brazil, Colombia, Russia and other countries and regions.



Contents

1. Overview of closed loop stepping technology

Introduction to closed loop stepping technology.....1

2. Closed-loop stepping drive and motor

Closed loop stepping and selection.....2

Closed loop stepping drive parameter list.....3

Closed loop stepping drive 2LS556A-42.....4

Closed loop stepping drive 2LS556A.....5

Closed loop stepping drive 2LS860H.....6

Closed loop stepping drive 3LS2280.....7

Closed loop stepping motor 42 57 60 86.....9

Three-phase Closed loop stepping motor 110 130.....10

3. Digital stepping drive and motor

Stepping product introduction.....11

Digital stepping driver and selection.....12

42 stepping drive 2NS422.....13

57 60 stepping drive 2NS556C.....14

57 60 stepping drive 2NS556A.....15

86 stepping drive 2NS860H.....16

86 110 stepping drive 3NS2250.....17

110 130 stepping drive 3NS2280.....18

42 series stepping motor.....20

57 60 series stepping motor.....21

86 series stepping motor.....22

110 130 series stepping motor.....24

Stepping motor torque frequency characteristic curve.....25

4. Special stepping drive

IO controlled stepping driver.....27

RS485 bus type stepping driver 2LS860R.....28

Introduction to closed loop stepping technology

Do not lose step

Use of photoelectric encoder feedback motor position constitutes a closed-loop stepping drive system; The traditional stepping motor drive system may cause lost step or stall during sudden load, so it is necessary to reserve a large torque margin; and the closed loop stepping driver will collect the current position information every 50us, and according to the position error information adjusts the current, corrects the position, and prevents step loss.

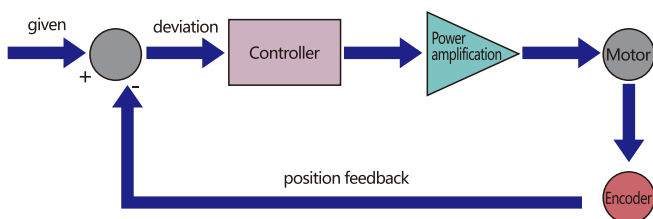

High torque

Ordinary stepping drive systems typically require a 30% torque margin to prevent lost step. Closed-loop stepping can use 100% of the motor torque to improve efficiency. Closed-loop stepping According to the position of the motor detected by the encoder, the magnitude and phase of the current are adjusted during overload, so that the torque of the motor at the current speed is kept to a maximum

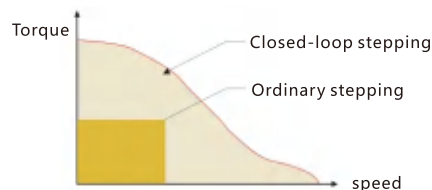

Stop without oscillation

The traditional servo system is an error tracking system. When reaching the target position, the error is close to zero, the torque fluctuates in a certain range, causing the shaft to oscillate; and the closed-loop stepping system utilizes the low-speed large torque characteristics of the stepping motor when the motor reaches the target position. No oscillation will occur. This feature is suitable for visual inspection applications

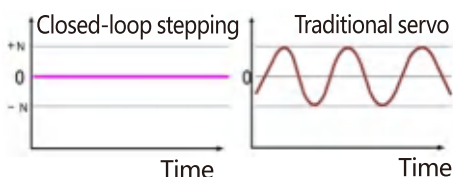

Fast response

The characteristic of the stepping motor is that the rotor is synchronized with the given pulse to achieve fast positioning. Suitable for quick positioning of short distances. The position sampling speed of traditional servo systems is slow and there is a large settling time.

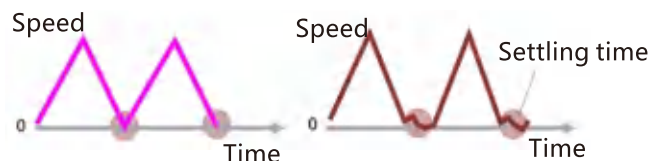

No gain adjustment

Traditional servo systems require complex, lengthy, and time-consuming various gain tunings depending on the load. Closed-loop stepping utilizes the unique torque characteristics of a stepping motor to match the encoder's position correction, enabling stable and reliable performance without the need for complex gain tuning. Particularly suitable for low rigidity loads (eg pulley drive systems).

Low heat

An ordinary stepping drive system operates with a constant current. The closed loop stepping drive system adjusts the current according to the load fluctuation. Can reduce heat, improve energy efficiency.

Closed loop stepping and selection

The closed-loop stepping drive of Bergerda is based on an ordinary open-loop stepping motor combined with position feedback and servo algorithm to form a high-speed, high-torque, high-precision, low-vibration, low-heat, No-lose-step stepping scheme. LS series stepping servo driver, based on the platform of 32-bit ARM processing chip, utilizes magnetic field orientation (FOC) and weak magnetic control algorithm design in servo driver, and has all-round performance beyond ordinary stepping.

- Built-in PID parameter adjustment function enables the motor to better meet the application of different types of loads.
- Built-in field weakening control algorithm reduces the magnetic field characteristics of the motor at high speed and maintains power.
- Built-in current vector control function makes the motor have servo current characteristics and low heat generation.
- Built-in micro-step instruction algorithm, so that the motor speed stage to maintain stable, low vibration.
- Built-in 4000pulse resolution encoder feedback, so that the motor accuracy, never lost step.

The servo control solution combined with the characteristics of the stepping motor enables the LS series closed-loop stepping driver to better perform the performance of the stepping motor and replace the same power servo application, making the automation equipment the most cost-effective new choice.

Application: It is especially good for users who want small noise and high speed equipment. For example: engraving machine, stripping machine, marking machine, cutting machine, solid crystal machine, plotter, CNC machine tools, automatic assembly equipment.

Drive function description

Drive function	Instructions
Command pulse form	The standard LS series driver signal interface is in pulse form and can accept two types of pulse command signals; 1. Pulse & Direction (PUL + DIR); 2. Double Pulse (CW + CCW);
output signal	It can be set to alarm output by parameter, positioning completion output, brake output; default is alarm output and positioning completion output.
Control algorithm is optional	The leading space vector servo control algorithm and the traditional advance angle control algorithm are optional, and the user can arbitrarily select according to the occasion.
External display	The DISPLAY interface can be connected to the display for easy setting of parameters and observation of operating conditions.
Wide voltage range on Signal terminal	Pulse, direction and enable signal input interface voltage 5V and 24V separate terminals, simple wiring, strong anti-interference ability
Seven status LED displays	The LS series driver has two operating states and five fault LED indication functions, allowing the user to clearly confirm the status of the driver.

Drive motor combination list

Motor frame	Motor model	Rated torque	Encoder line specification	Supporting drive model
42	42BG04-EC	0.48NM	lead line 3 meters	2LS556A
42	42BG06-EC	0.72NM	lead line 3 meters	2LS556A
57	57BG10-EC	1.0NM	lead line 3 meters	2LS556A
57	57BG20-EC	2.0NM	lead line 3 meters	2LS556A
60	60BG30-EC	3.0NM	lead line 3 meters	2LS556A
86	86BG40-EC	4.5NM	lead line 3 meters	2LS860H
86	86BG80-EC	8.5NM	lead line 3 meters	2LS860H
86	86BG120-EC	12NM	lead line 3 meters	2LS860H

Note: 1. Standard model motor directly out of the 3 meter encoder line

2. Non-standard model closed-loop motor suffix plus L such as :57BG20-ECL(body outlet length 500mm) extension cord with other models:L-030

Closed-loop stepping drive naming method

2 LS 5 — 56 — A
 ① ② ③ ④ ⑤

- ① 2 is two phases, 3 is three phase
- ② Closed loop stepping
- ③ Maximum input power supply voltage DC50V
- ④ Maximum output current 5.6A
- ⑤ Version code

Closed-loop stepping motor naming method

57 BG 20 — EC — Z
 ① ② ③ ④ ⑤

- ① Frame size
- ② Two-phase BG, three-phase BS
- ③ Torque X0.1Nm
- ④ Encoder line number EC: 1000 lines
- ⑤ Special code, Z: brake

Closed loop stepping drive parameter list

Parameter No.	definition	function	Factory default
0	Maximum current value	Set the maximum output current of the driver	72
1	Light load current ratio	Set the operating current to maximum current ratio at light load. When the load can be driven, the lower setting is beneficial to reduce the heating of the motor.	50
2	Input signal logic inversion	Input inversion	0
3	Output signal logic inversion	1: Output port 1 logic inversion 2: Output port 2 logic inversion	0
4	Output port 1 function definition (corresponding to silk screen pend)	0: Alarm 1: Brake 2: Positioning completed	2
5	Output port 2 function definition	0: Alarm 1: Brake 2: Positioning completed	0
6	Positioning completion range setting	The position deviation is lower than the set value output positioning completion signal	20
7	Number of encoder lines	Encoder one revolution pulse number	1000
8	Position error alarm setting	When the position deviation is higher than the set value, the drive output position is out of tolerance alarm	4000
9	Pulse command smoothing	When the input pulse frequency is low, the setting is larger, which makes the motor run more smoothly (the dialing S6 switch can be turned off)	500
10	Drive proportional gain		80
11	Drive proportional integral	When the input pulse frequency is low, the setting is larger, which makes the motor run more smoothly (the dialing S6 switch can be turned off)	15
12	Position ac/deceleration coefficient	0: No ac/deceleration. For other values, the smaller the value, the slower the ac/deceleration	
14	Off enable delay time	After off the enable, delay the brake time to ensure the brake is applied after the motor is excitation	100
15	Motor power line phase modulation	After motor power phase modulation, normal control can be realized without changing the phase sequence of the encoder.	0
20	Alarm record 0	Last alarm record	0
21	Alarm record 1	Second last alarm record	0
27	Alarm record 7	Countdown to the eighth alarm record	0
30	Drive version		106
31	Motor code	42BG04-EC:4 42BG06-EC:3 57BG20-EC:0 86BG80-EC:6	

Display interface:

No.	content	definition
1	r	Rotating speed
2	i	Current
3	c	Command position
4	E	Encoder wheel position
5	d	Position deviation
6	d .	Position deviation after acceleration and deceleration
7	IO	The status of the input and output signals is displayed from right to left. The upper part of the digital tube is on and off: d1: enable d2: direction d3: pulse d5: output 1 d6: output 2
8	EE-OP	Press Enter to restore the default value, it takes a while
9	PA	Display and modify individual parameters

Closed loop stepping driver 2LS556A -42

Based on the platform of 32-bit ARM processing chip, the magnetic field orientation and high-speed flux-weakening algorithm in the servo driver are designed to achieve excellent performance.

The built-in vector control design and servo demodulation function of the driver, combined with the feedback of the closed-loop motor encoder, make the stepping servo system have the features of low noise, low heating, no lost steps and higher application speed, and can improve the intelligent equipment system performance in all directions.

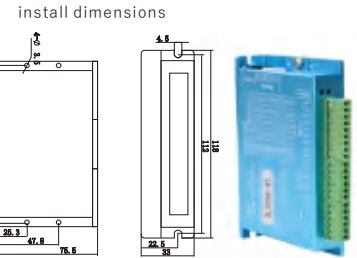

- Pulse mode: single pulse/ CW/CCW pulse
- Signal level: 5V/24V separate wiring, simple and practical, strong anti-interference ability.
- Typical applications: lock screw machine, servo dispensing machine, stripping machine, labeling machine, medical detector, electronic assembly equipment, etc. The application effect is particularly good in a device where the user desires high rotation speed and high torque.

Drive function description

Drive function	Operating Instructions
Microstep subdivision setting	SW1-SW4 four dial codes are used to select a total of 16 files of microsteps. When the user sets the subdivision, electric motion should be stopped first. For detailed microstep subdivision settings, please see the drive panel description.
Running direction setting	SW5 is used to select the initial direction of rotation of the motor. It is necessary to power off and restart the drive to make effect.
Pulse smoothing selection	SW6 is used to select whether to enable the internal S-type command smoothing function. Turn on this function when ON to make the driver input pulse signal smoother. It is necessary to power off and restarts the drive to make effect.
Pulse mode selection	SW7 is used to select the input pulse mode, off is the pulse & direction, and on is CW/CCW pulse. It is necessary to power off and restart the drive to make effect.
Open/closed loop selection	SW8 is used to select the control mode, off is the closed loop mode, and on is the open loop mode.
Pulse control / automatic operation selection	SW9 pulse control / automatic operation select off: Receive external pulse control, on drive automatically with 20RPM automatic forward and reverse, can be used to test the motor and drive
Signal interface	PUL+ and PUL- are the positive and negative ends of the control pulse signal; DIR+ and DIR- are the positive and negative ends of the direction signal; ENA+ and ENA- are the positive and negative ends of the enable signal; ALM+ and ALM- are the Positive and negative ends of alarm output signals. The ALM port can also be configured for brake output or positioning completion.
Encoder interface	EB+ and EB- are encoder B direction signals; EA+ and EA- are encoder A direction signals; VCC and GND are encoder power interfaces.
Motor interface	A+, A-, B+, B- are the stepping servo motor winding interfaces, which must be linked with the motor identification color and cannot be exchanged.If the phase sequence of the encoder and motor power line is reversed, you can change the parameter resolution.
Power interface	V+, V- are the positive and negative terminals of the input DC power supply, 2LS556A operating voltage range 24-50 VDC, voltage power greater than 150W.
LED	The driver has two indicators, red and green. The green light is the power indicator. The green light flashes after the driver is powered on. The red light is the fault indicator. The red light flickers when there is a fault in the gear and the encoder is misaligned. After the fault is cleared, the red light goes out. When an alarm occurs on the drive, it must be powered on again to clear the fault.
Installation Notes	Dimensions: 118 * 75.5 * 33 mm, mounting hole spacing 112. Can be horizontal or vertical installation, but it should be close to the metal cabinet for better cooling

Driver operating status LED indication

LED status	Drive status
● Green light	Drive is not enabled
●● Green flashing	The driver is working properly(Pulse flashing faster)
●●● 1green, 1red	Drive overcurrent
●●●● 1 green, 2 red	Encoder counter or no encoder
●●●●● 1 green, 3 red	Location out of tolerance
●●●●●● 1 green, 5 red	ADC hardware error

Microstep subdivision setting

Steps / Turn	SW1	SW2	SW3	SW4
3600	on	on	on	on
800	off	on	on	on
1600	on	off	on	on
3200	off	off	on	on
6400	on	on	off	on
12800	off	on	off	on
25600	on	off	off	on
7200	off	off	off	on
1000	on	on	on	off
2000	off	on	on	off
4000	on	off	on	off
5000	off	off	on	off
8000	on	on	off	off
10000	off	on	off	off
20000	on	off	off	off
40000	off	off	off	off

Driver cable diagram

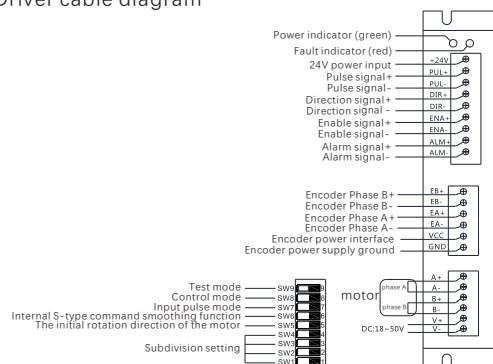

Closed loop stepping driver 2LS556A

Based on the platform of 32-bit ARM processing chip, the magnetic field orientation and high-speed flux-weakening algorithm in the servo driver are designed to achieve excellent performance.

The built-in vector control design and servo demodulation function of the driver, combined with the feedback of the closed-loop motor encoder, make the stepping servo system have the features of low noise, low heating, no lost steps and higher application speed, and can improve the intelligent equipment system performance in all directions.

install dimensions

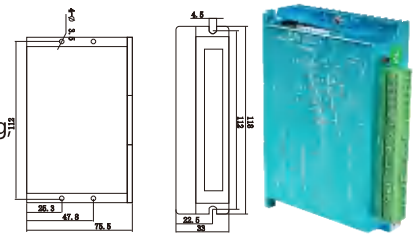

- Pulse mode: single pulse/ CW/CCW pulse
- Signal level: 5V/24V separate wiring, simple and practical, strong anti-interference ability.
- Typical applications: lock screw machine, servo dispensing machine, stripping machine, labeling machine, medical detector, electronic assembly equipment, etc. The application effect is particularly good in a device where the user desires high rotation speed and high torque.

Drive function description

Drive function	Operating Instructions
Microstep subdivision setting	SW1-SW4 four dial codes are used to select a total of 16 files of microsteps. When the user sets the subdivision, electric motion should be stopped first. For detailed microstep subdivision settings, please see the drive panel description.
Running direction setting	SW5 is used to select the initial direction of rotation of the motor. It is necessary to power off and restart the drive to make effect.
Pulse smoothing selection	SW6 is used to select whether to enable the internal S-type command smoothing function. Turn on this function when ON to make the driver input pulse signal smoother. It is necessary to power off and restarts the drive to make effect.
Pulse mode selection	SW7 is used to select the input pulse mode, off is the pulse & direction, and on is CW/CCW pulse. It is necessary to power off and restart the drive to make effect.
Open/closed loop selection	SW8 is used to select the control mode, off is the closed loop mode, and on is the open loop mode.
Pulse control / automatic operation selection	SW9 pulse control / automatic operation select off: Receive external pulse control, on drive automatically with 20RPM automatic forward and reverse, can be used to test the motor and drive
Signal interface	PUL+ and PUL- are the positive and negative ends of the control pulse signal; DIR+ and DIR- are the positive and negative ends of the direction signal; ENA+ and ENA- are the positive and negative ends of the enable signal; ALM+ and ALM- are the Positive and negative ends of alarm output signals. The ALM port can also be configured for brake output or positioning completion.
Encoder interface	EB+ and EB- are encoder B direction signals; EA+ and EA- are encoder A direction signals; VCC and GND are encoder power interfaces.
Motor interface	A+, A-, B+, B- are the stepping servo motor winding interfaces, which must be linked with the motor identification color and cannot be exchanged.If the phase sequence of the encoder and motor power line is reversed, you can change the parameter resolution.
Power interface	V+, V- are the positive and negative terminals of the input DC power supply, 2LS556A operating voltage range 24-50 VDC, voltage power greater than 150W.
LED	The driver has two indicators, red and green. The green light is the power indicator. The green light flashes after the driver is powered on. The red light is the fault indicator. The red light flickers when there is a fault in the gear and the encoder is misaligned. After the fault is cleared, the red light goes out. When an alarm occurs on the drive, it must be powered on again to clear the fault.
Installation Notes	Dimensions: 118 * 75.5 * 33 mm, mounting hole spacing 112. Can be horizontal or vertical installation, but it should be close to the metal cabinet for better cooling

Driver operating status LED indication

LED status	Drive status
● Green light	Drive is not enabled
●● Green flashing	The driver is working properly(Pulse flashing faster)
●●● 1green, 1red	Drive overcurrent
●●●● 1 green, 2 red	Encoder counter or no encoder
●●●●● 1 green, 3 red	Location out of tolerance
●●●●●● 1 green, 5 red	ADC hardware error

Microstep subdivision setting

Steps / Turn	SW1	SW2	SW3	SW4
3600	on	on	on	on
800	off	on	on	on
1600	on	off	on	on
3200	off	off	on	on
6400	on	on	off	on
12800	off	on	off	on
25600	on	off	off	on
7200	off	off	off	on
1000	on	on	on	off
2000	off	on	on	off
4000	on	off	on	off
5000	off	off	on	off
8000	on	on	off	off
10000	off	on	off	off
20000	on	off	off	off
40000	off	off	off	off

Driver cable diagram

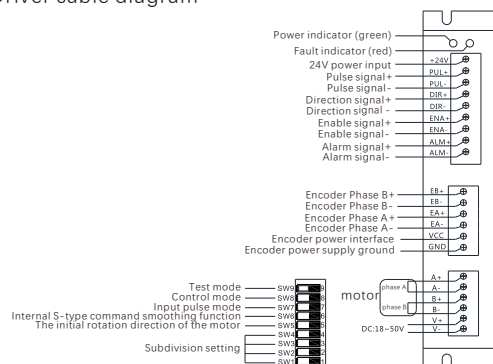

Closed loop stepping driver 2LS860H

Based on the platform of 32-bit ARM processing chip, the magnetic field orientation and high-speed flux-weakening algorithm in the servo driver are designed to achieve excellent performance.

The built-in vector control design and servo demodulation function of the driver, combined with the feedback of the closed-loop motor encoder, make the stepping servo system have the features of low noise, low heating, no lost steps and higher application speed, and can improve the intelligent equipment system performance in all directions.

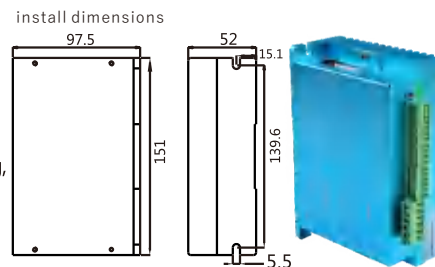

- Pulse mode: single pulse/ CW/CCW pulse
- Signal level: 5V/24V separate wiring, simple and practical, strong anti-interference ability.
- Typical applications: lock screw machine, servo dispensing machine, stripping machine, labeling machine, medical detector, electronic assembly equipment, etc. The application effect is particularly good in a device where the user desires high rotation speed and high torque.

Drive function description

Drive function	Operating Instructions
Microstep subdivision setting	SW1-SW4 four dial codes are used to select a total of 16 files of microsteps. When the user sets the subdivision, electric motion should be stopped first. For detailed microstep subdivision settings, please see the drive panel description.
Running direction setting	SW5 is used to select the initial direction of rotation of the motor. It is necessary to power off and restart the drive to make effect.
Pulse smoothing selection	SW6 is used to select whether to enable the internal S-type command smoothing function. Turn on this function when ON to make the driver input pulse signal smoother. It is necessary to power off and restarts the drive to make effect.
Pulse mode selection	SW7 is used to select the input pulse mode, off is the pulse & direction, and on is CW/CCW pulse. It is necessary to power off and restart the drive to make effect.
Open/closed loop selection	SW8 is used to select the control mode, off is the closed loop mode, and on is the open loop mode.
Pulse control / automatic operation selection	SW9 pulse control / automatic operation select off: Receive external pulse control, on drive automatically with 20RPM automatic forward and reverse, can be used to test the motor and drive
Signal interface	PUL+ and PUL- are the positive and negative ends of the control pulse signal; DIR+ and DIR- are the positive and negative ends of the direction signal; ENA+ and ENA- are the positive and negative ends of the enable signal; ALM+ and ALM- are the Positive and negative ends of alarm output signals. PEND+ and PEND- are the positive and negative ends of the in-position output signal. The ALM port can also be configured for brake output or positioning completion.
Encoder interface	EB+ and EB- are encoder B direction signals; EA+ and EA- are encoder A direction signals; VCC and GND are encoder power interfaces.
Motor interface	A+, A-, B+, B- are the stepping servo motor winding interfaces, which must be linked with the motor identification color and cannot be exchanged. If the phase sequence of the encoder and motor power line is reversed, you can change the parameter resolution.
Power interface	AC and AC are universal inputs for AC and DC power supplies. 2LS860H operating voltage range 18-80VAC or 24-100VDC, voltage power greater than 200W.
LED	The driver has two indicators, red and green. The green light is the power indicator. The green light flashes after the driver is powered on. The red light is the fault indicator. The red light flickers when there is a fault in the gear and the encoder is misaligned. After the fault is cleared, the red light goes out. When an alarm occurs on the drive, it must be powered on again to clear the fault.
Installation Notes	Dimensions: 151 * 97.5 * 52mm, mounting hole spacing 139.6. Can be horizontal or vertical installation, but it should be close to the metal cabinet for better cooling

Driver operating status LED indication

LED status	Drive status
● Green light	Drive is not enabled
●● Green flashing	The driver is working properly(Pulse flashing faster)
●● Green, 1 red	Drive overcurrent
●● Green, 2 red	Encoder counter or no encoder
●● Green, 3 red	Location out of tolerance
●● Green, 5 red	ADC hardware error

Driver cable diagram

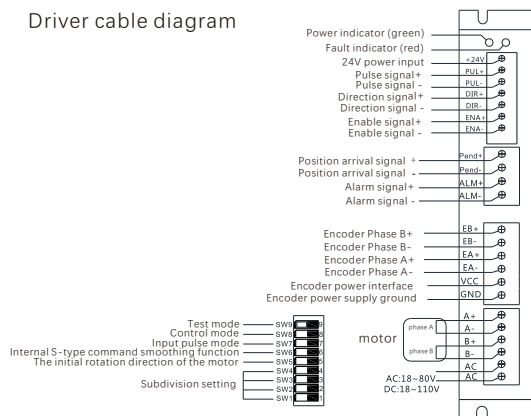

Microstep subdivision setting

Steps / Turn	SW1	SW2	SW3	SW4
3600	on	on	on	on
800	off	on	on	on
1600	on	off	on	on
3200	off	off	on	on
6400	on	on	off	on
12800	off	on	off	on
25600	on	off	off	on
7200	off	off	off	on
1000	on	on	on	off
2000	off	on	on	off
4000	on	off	on	off
5000	off	off	on	off
8000	on	on	off	off
10000	off	on	off	off
20000	on	off	off	off
40000	off	off	off	off

110 130 closed loop stepping driver 3LS2280

Product Description

Based on ARM new 32-bit DSP processing chip platform, the internal PID current control algorithm design, with excellent performance. The built-in micro-segmentation technology and the automatic tuning function of the power-on parameter make the driver have the characteristics of low noise, low vibration, low heat generation and high-speed high torque output. In addition, the patented three-phase demodulation algorithm can give full play to the low-speed resonance and small torque ripple characteristics of the phase stepping motor, and can be well adapted to applications requiring higher stability.

- Pulse mode: single pulse/ CW/CCW pulse
- Signal level: 5V/24V separate wiring, simple and practical, strong anti-interference ability.
- Typical applications: potting machines, engraving machines, cutting machines, laser equipment, CNC machine tools, automatic equipment and so on. The application effect is particularly good in a device where the user desires high speed and small noise.

install dimensions

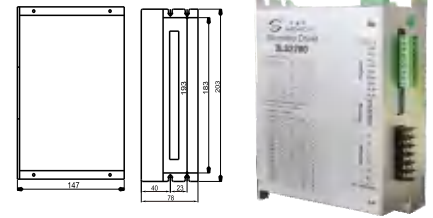

Drive function description

Drive function	Operating Instructions
Microstep subdivision setting	SW5-SW8 four dial codes are used to select a total of 16 files of microsteps. When the user sets the micro step, driver should be stopped first. For detailed microstep subdivision settings, please see the drive panel description.
Output current setting	SW1-SW3 three dial switches are used to select a total of 8 output currents. For the specific output current setting, please see the driver panel description.
Pulse smoothing filter	The SW4 dial code is used to select the pulse smoothing function of the drive, the off means the off function, and on means the function is turned on.
Pulse form selection	SW9 dial code is used to select the pulse form, off: pulse + direction ON: CW/CCW
Signal interface	PUL+ and PUL- are the positive and negative ends of the control pulse signal; DIR+ and DIR- are the positive and negative ends of the direction signal; ENA+ and ENA- are the positive and negative ends of the enable signal; ALM+ and ALM- are the positive and negative terminals of the alarm output signal; PLC control only needs to connect +24V, Pul- DIR three lines.
Encoder interface	EB+ and EB- are encoder B direction signals; EA+ and EA- are encoder A direction signals; VCC and GND are encoder power interfaces.
Motor interface	U, V, W butt the motor windings U, V, W, Arbitrarily swapping two of the three winding wires can change the direction of the motor., PE ground wire.
Power interface	The working voltage range is recommended for AC 110-230V. It is recommended to add a filter (EMI FILTER) before the power supply circuit.
LED	The driver has two indicators, red and green. The green light is the power indicator. The green light flashes after the driver is powered on. The red light is the fault indicator. The red light flickers when there is a fault in the gear and the encoder is misaligned. After the fault is cleared, the red light goes out. When an alarm occurs on the drive, it must be powered on again to clear the fault.

Installation Notes Dimensions: 183 * 144 * 48mm, mounting hole spacing 156mm. Can be horizontal or vertical installation, but it should be close to the metal cabinet for better cooling

Driver operating status LED indication

LED status	Drive status
●● Green flashing	The driver is working properly (pulse input flashes faster)
●● 1green, 1red	Drive overcurrent
●● 1 green, 2 red	The code wheel is reversed or there is no code dial (you can change the parameter NO.15)
●● 1 green, 3 red	Position error (closed loop)
●● 1 green, 4 red	IPM Alarm
●● 1 green, 5 red	ADC hardware error

Output current peak	Output current Rms	SW1	SW2	SW3
3.9A	depend by PA5 parameter	on	on	on
5.0A	3.6A	off	on	on
6.3A	4.5A	on	off	on
7.6A	5.4A	off	off	on
8.7A	6.2A	on	on	off
9.8A	7.0A	off	on	off
11.2A	8.0A	on	off	off
12.6A	9.0A	off	off	off

Driver cable diagram

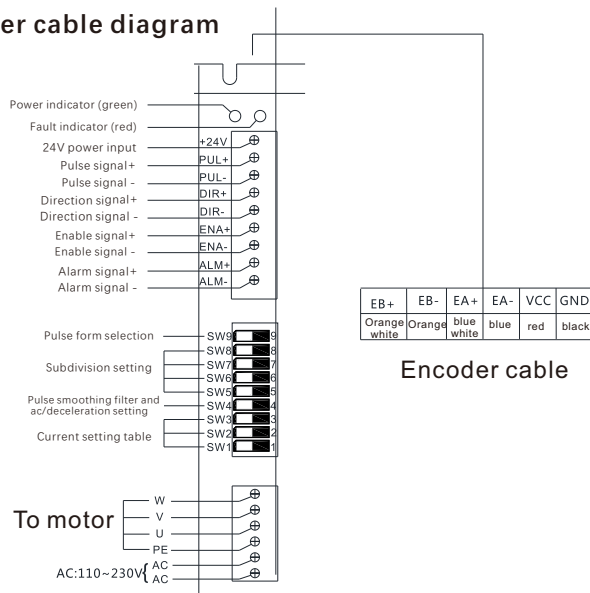

Microstep subdivision setting

Steps / Turn	SW5	SW6	SW7	SW8
200	on	on	on	on
400	off	on	on	on
600	on	off	on	on
800	off	off	on	on
1000	on	on	off	on
1200	off	on	off	on
2000	on	off	off	on
3000	off	off	off	on
4000	on	on	on	off
5000	off	on	on	off
6000	on	off	on	off
10000	off	off	on	off
12000	on	on	off	off
20000	off	on	off	off
30000	on	off	off	off
8000	off	off	off	off

110 130 closed loop stepping driver 3LS2280

Parameter list

No.	Definition	Function	Default
1	Light load current ratio	Minimum current and maximum current percentage (closed loop use)	50%
2	Input signal logic negation	Input (enable) negation	0
3	Output signal logic negation	Output negation	0
4	Motor action time after enable	0: Run after 0.5 seconds after enable 1: Run directly after enable	1
5	Rated current of motor operation	When the current selection switches SW1, SW2, and SW3 are all ON, the rated current of the drive runs according to the value set by this parameter, and the value is the effective value. Unit*0.01A	276
6	Positioning completion range setting	Position deviation is lower than this set value and output positioning completion signal	20
7	Encoder line	Requires an integer multiple of 50 after 4 octave	1000
8	Position out-of-tolerance alarm setting	When the position deviation is higher than the set value, the drive output position out of tolerance alarm	4000
9	Pulse command smoothing Filtering	When the input pulse frequency is low, set it larger to make the motor run more smoothly. Use parameter data when SW4 is ON	20
10	Current proportional gain	The larger the setting, the higher the gain, and the smaller the current tracking error. However, if the gain is too large, oscillation or noise will occur.	140
11	Current proportional integral	The smaller the setting, the faster the integration speed and the smaller the current tracking error.	100
12	Position Ac/deceleration coefficient	When SW4 is ON, 0: No ac/deceleration. For other values, the smaller the value, the shorter the acceleration/deceleration time.	80
13	Half wave function	Turn on half wave function (for open loop) 0: full flow 1: half flow	1
15	Motor power line phase modulation	After motor power phase adjustment, normal control can be achieved without changing the phase sequence of the encoder.	0
16	Closed-loop control compensation		245
17	Invert position command	0: Normal; 1: Reverse direction	0
18	Test run	0: external pulse; 1: automatic operation	0
19	open-loop control compensation		400
20	alarm record0	Last alarm record	0
21	alarm record1	The penultimate alarm record	0
...
27	alarm record 7	Eighth to last alarm record	0
28~29	System use	Reserved for factory use	
30	Drive version	Reserved for factory use	108

Show interface:

No.	content	Definition
1	r	Speed
2	i	Current
3	c	Instruction position
4	E	Encoder position
6	d	5 positions lower
7	d .	High position deviation
8	IO	Port information (from right to left are enable, direction, pulse, blank, alarm)
9	EE-OP	Press Enter to restore the default value, it takes a while
10	PA	Display and modify various parameters

Closed loop stepping motor 42 57 60 86



42BG04-EC

57BG10-EC
57BG20-EC

60BG30-EC

86BG40-EC
86BG80-EC

Technical specifications

model	Phase	Step angle (°)	Holding torque N·M	Rated current A	Phase inductance mH	Phase resistance Ohm	Number of leads	Rotor inertia (g·cm ²)	Shaft diameter mm	Encoder resolution	Body length (L) mm
42BG04-EC	2	1.8	0.48	2.0	2.9	1.35	4	77	5	1000	68
42BG06-EC	2	1.8	0.72	2.0	4.0	1.75	4	110	5	1000	80
57BG10-EC	2	1.8	1.0	2.8	1.2	0.8	4	260	8	1000	77
57BG20-EC	2	1.8	2.0	4.0	1.8	0.8	4	460	8	1000	98
60BG30-EC	2	1.8	3.0	5.0	1.8	0.45	4	690	8	1000	108
86BG40-EC	2	1.8	4.5	6.0	3.5	0.8	4	1400	14	1000	98
86BG80-EC	2	1.8	8.5	6.0	5.2	0.95	4	2800	14	1000	136
86BG120-EC	2	1.8	12.0	6.0	8.6	0.73	4	4000	14	1000	172

42 Series Size

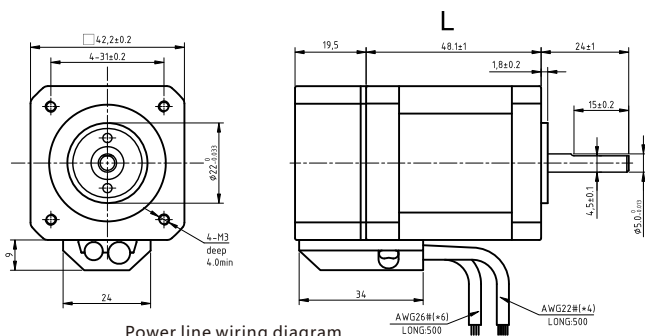

Power line wiring diagram

A+	A-	B+	B-
red	blue	green	black

57 Series Size

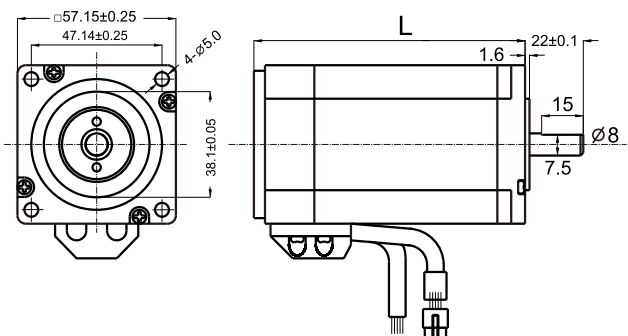

Xq encoder wiring diagram

EB+	EB-	EA+	EA-	VCC	GND
Orange white	Orange	Blue white	Blue	Red	Black

Power line wiring diagram

A+	A-	B+	B-
red	blue	green	black

60 Series Size

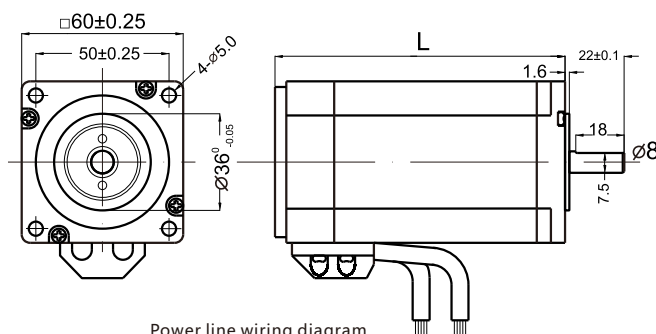

Power line wiring diagram

A+	A-	B+	B-
red	blue	green	black

86Series Size

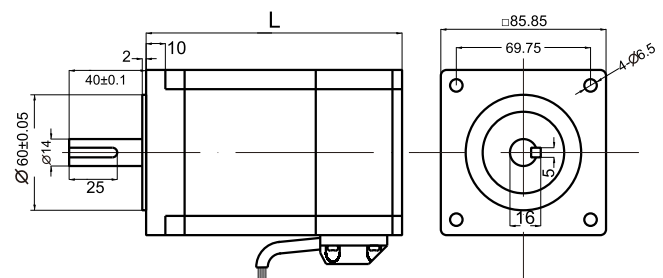

Power line wiring diagram

A+	A-	B+	B-
red	yellow	black	green

110 130 series three-phase closed loop stepper motor

General specifications

Step accuracy	±5% (Whole step, Empty load)
Temperature rise	80 °C Max
Ambient temperature	-10 °C — +50 °C
Insulation resistance	100MΩmin. 500VDC
Pressure resistance	500VAC for one minute
Radial runout	0.06 Max. (450g-load)
Axial runout	0.08 Max. (450g-load)



Technical specifications

Model	Phase	Step angle (°)	Holding torque N.M	Rated current A	Phase inductance mH	Phase resistance Ohm	Number of leads	Rotor inertia (g.cm ²)	Shaft diameter mm	Motor weight Kg	Body length L (mm)
3H110BG120-EC	3	1.2	12	6.0	8.34	1.89	3	9.7	19	6.6	151
3H110BG160-EC	3	1.2	16	6.5	8.73	1.89	3	13.6	19	9.0	185
3H110BG200-EC	3	1.2	20	6.9	7.26	1.859	3	17.4	19	11.1	219
3H130BG230-EC	3	1.2	23	5.0	7.05	1.46	3	23.4	24	12.3	168
3H130BG360-EC	3	1.2	35	6.0	6.14	1.26	3	26.2	24	14.6	225
3H130BG500-EC	3	1.2	50	6.0	3.26	0.96	3	39.4	24	17.4	280

Dimensions(mm)

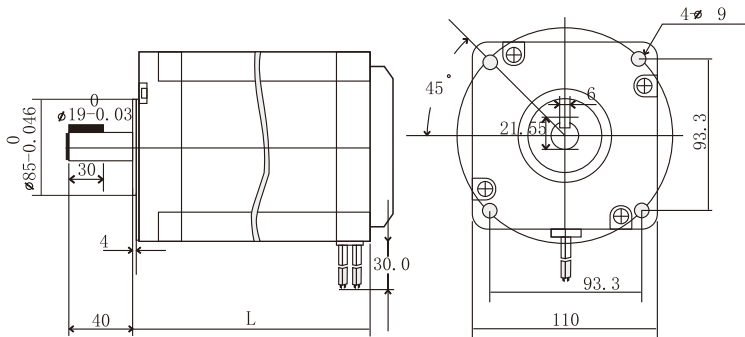

Dimensions(mm)

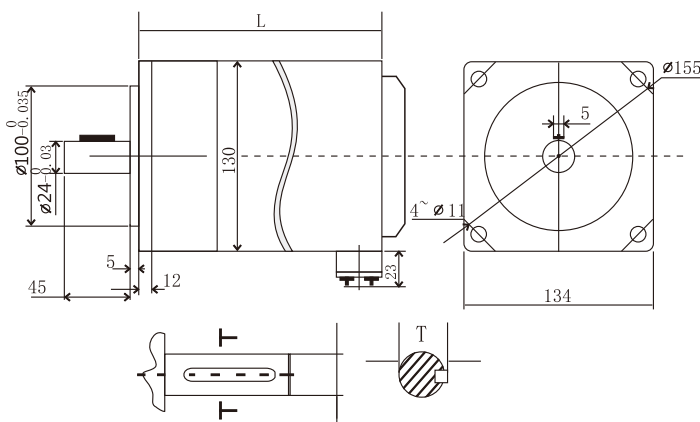

T = 21
KEY=5×5×30

Wiring diagram

Drive wiring	Corresponding motor lead
U	1
V	2
W	3
PE	4

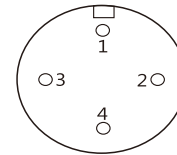

Wiring diagram

Drive wiring	Corresponding motor lead
U	U
V	V
W	W
PE	PE

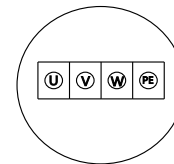

Motor rear cover wiring diagram

Encoder wiring diagram

EB+	EB-	EA+	EA-	VCC	GND
Orange white	Orange	Blue white	Blue	Red	Black

Stepping product introduction

Working principle of stepping products

Stepper motor is a special motor specially used for position and speed precision control. The biggest feature of stepper motors is "digital" and "error accumulation." For each pulse signal sent by the controller, the stepper motor rotates a fixed angle under the action of its driver, and the rotation of the stepper motor runs step by step at this fixed angle. We can control the angular displacement by controlling the number of pulses, so as to achieve the purpose of accurate positioning; at the same time, we can control the speed and acceleration of the motor rotation by controlling the pulse frequency, so as to achieve the purpose of speed regulation. It is widely used in various open-loop control by using the characteristic of stepping motor without accumulated error.



Types of stepping motors

There are three main types of stepper motors in construction: reactive (VR), permanent magnet (PM) and hybrid (HS).

VR: There are windings on the stator and the rotor is composed of soft magnetic materials. The structure is simple, the cost is low, and the step angle is small, up to 1.2°. However, the dynamic performance is poor, the efficiency is low, the heat is large, and the reliability is difficult to guarantee.

PM: The rotor of the permanent magnet stepping motor is made of permanent magnet material, and the number of poles of the rotor is the same as that of the stator. Its characteristics are good dynamic performance and large output torque, but this kind of motor has poor accuracy and large step angle (generally 7.5° or 1.5°).

HS: The hybrid stepping motor combines the advantages of reactive and permanent magnets. Its stator has multi-phase windings and the rotor uses permanent magnet materials. There are multiple small teeth on the rotor and stator to improve the stepping accuracy. It is characterized by large output torque, good dynamic performance, and small step angle, but its structure is complex and the cost is relatively high. According to the winding on the stator, there are two-phase (1.8°), three-phase (1.2°) and five-phase (0.72°) series. The most popular is the two-phase hybrid stepper motor, which accounts for more than 97% of the market share. The reason is that it is cost-effective, and the effect is good when equipped with a subdivision driver.

Features of stepper motors

1. Quick start and stop, frequent forward and reverse rotation
2. The control is precise, the number of pulses determines the position of the motor
3. Convenient speed adjustment, pulse frequency determines the motor speed
4. High torque, high speed response and light weight
5. Subdivision driven, high accuracy and low price
6. Long service life and low maintenance cost

Common terminology of stepper motor

1. **Step angle:** The angle that the rotor rotates every time an electrical pulse signal is input is called the step angle. The step angle can directly affect the running accuracy of the motor.
2. **Full-step:** the most basic driving mode. Each pulse in this driving mode makes the motor move a basic step angle. In the full-step driving mode, each pulse makes the motor move 1.8°.
3. **Half step:** During single-phase excitation, the motor shaft stops to the full step position. After the driver receives the next pulse, if the other phase is excited and the original phase continues to be in the state of excitation, the motor shaft will move halfway A basic step angle, stopping in the middle of two adjacent full-step positions. In this way, single-phase and then dual-phase excitation of the two-phase coils is performed cyclically. The stepper motor will rotate at half a basic step angle per pulse.
4. **Subdivision:** Subdivision means that the actual step angle when the motor is running is a fraction of the basic step angle. For example: when the drive is working in the state of 10 subdivision, its step angle is only one tenth of the inherent step angle of the motor, that is to say: when the drive is working in the full-step state without subdivision, the control system will send one In step pulse, the motor rotates 1.8°; when the subdivision driver is used in the 10 subdivision state, the motor only rotates 0.18°. The subdivision function is completely generated by the driver by accurately controlling the phase current of the motor, and has nothing to do with the motor.
5. **Static phase current:** the current allowed by each phase winding when the motor is not moving, that is, the rated current
6. **Holding torque:** refers to the torque that the stator locks the rotor when the stepper motor is energized but not rotating. It is one of the most important parameters of a stepper motor. Usually, the torque of a stepper motor at low speed is close to the holding torque. Since the output torque of a stepper motor decays continuously with the increase of speed, and the output power also changes with the increase of speed, the holding torque becomes one of the most important parameters to measure the stepper motor. For example, when people say that a 2N.m stepper motor, unless otherwise specified, it refers to a stepper motor with a holding torque of 2N.m.
7. **Braking torque:** refers to the torque that the stator locks the rotor when the stepper motor is not energized. There is no uniform translation method in China, which is easy to cause misunderstandings
8. **No-load starting frequency:** refers to the highest pulse frequency that the stepper motor can start without losing step.
9. **Maximum starting frequency:** The maximum frequency at which the motor can be started directly without load under a certain driving mode, voltage and rated current.
10. **Maximum operating frequency:** the maximum speed frequency of the motor without load under a certain driving mode, voltage and rated current
11. **Running torque-frequency characteristic:** The curve of the relationship between output torque and frequency measured under certain test conditions is called the running torque-frequency characteristic. This is the most important of the many dynamic curves of the motor and the basic basis for motor selection. . Other characteristics include inertia frequency characteristics, starting frequency characteristics and so on. Once the motor is selected, the static torque of the motor is determined, but the dynamic torque is not. The dynamic torque of the motor depends on the average current (not the static current) of the motor during operation. The larger the average current, the greater the output torque of the motor, that is, the motor's output torque. The harder the frequency characteristic is, the larger the average current is, the higher the drive voltage is, and the smaller the inductance and the larger the current motor.

Digital stepping driver and selection

The Bergerda series of digital stepping drivers, based on a 32-bit DSP platform, utilizes micro-segmentation technology and PID current control algorithm design to provide a full range of performance beyond the ordinary analog stepping drivers.

- PID parameter adjustment function to better meet different types of load applications
- Micro-segmentation control algorithm to improve the smoothness of the motor in each speed segment
- Command smoothing function makes the motor acceleration and deceleration process smoother
- Low speed vibration suppression, motor low speed resonance amplitude reduced by 80%
- Application fields: engraving machine, screw machine, stripping machine, marking machine, cutting machine, solid crystal machine, plotter, CNC machine tool, automatic assembly equipment, etc.

Stepping drive naming

2 NS 8 60 H

① ② ③ ④ ⑤

- ① 2 is two phases, 3 is three phase
- ② Digital stepping
- ③ Maximum input AC, 80V supply voltage
- ④ Output maximum current 6.0A
- ⑤ Version No A、C、H、IO

Technical specifications

model	Peak current	weight	Input voltage range	size	Number of subdivisions	Pulse level	Matching motor (Flange)
2NS422	2.2	106g	24-48VDC	92.6×56×21	200-25600	5/24V	20、28、35、39、42
2NS556A	5.6	300g	24-50VDC	118×76×33	400-51200	5/24V	57、60
2NS556C	5.6	300g	20V-40VAC	118×76×33	400-40000	5/24V	57、60
2NS860H	7.2	590g	24-80VAC	151×97×52	400-51200	5/24V	86
2NS860C	7.2	590g	24-80VAC	151×97×52	400-40000	5/24V	86
3NS2250	6.6	900g	110-240VAC	178x109x68	200-30000	5/24V	Three-phase 86/110
3NS2280	12.6	1345g	110-240VAC	203×147×78	200-30000	5/24V	Three-phase 110/130

Interface wiring

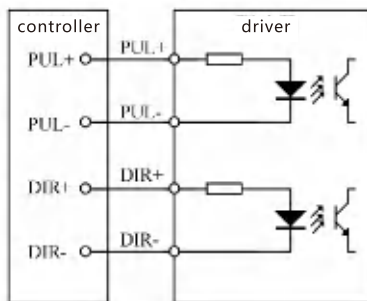

A 5V differential connection

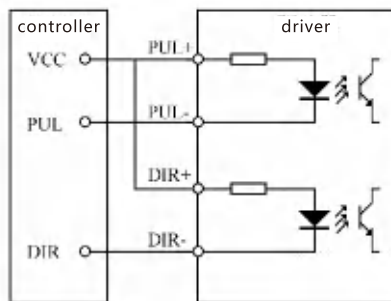

B 5V single-ended connection

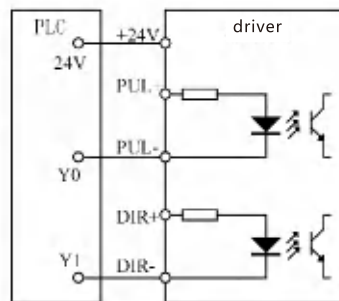

C PLC connection

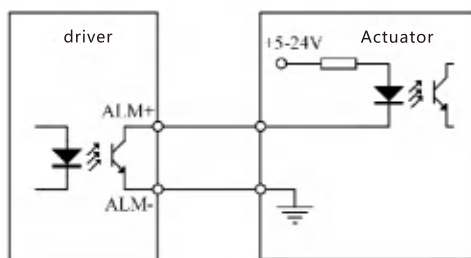

E Alarm output connection

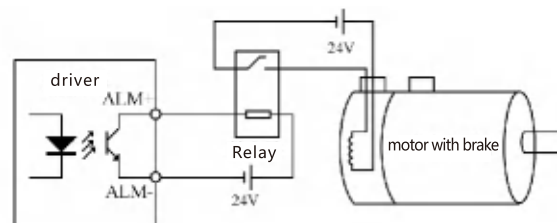

F Brake output connection

42 stepping driver 2NS422

Based on ARM's new 32-bit multi-channel DSP processing chip platform, using internal PID current control algorithm design, with excellent performance. The built-in micro-segmentation technology and the automatic tuning function of the power-on parameter make the driver have the characteristics of low noise, low vibration, low heat and high-speed high-moment output, and can be well adapted to most applications of stepping motors.

- Pulse mode: single pulse/CW/CCW pulse
- Signal level: 5V/24V separate wiring, simple and practical, strong anti-interference ability
- Typical applications: stripping machine, marking machine, cutting machine, laser equipment, visual positioning, automatic equipment and so on. The application effect is particularly good in a device where the user desires high speed and small noise.

Installation size:

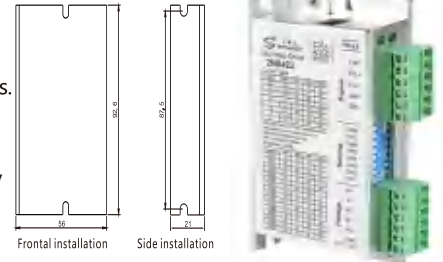

Drive function description

Drive function	Operating Instructions
Microstep subdivision setting	SW5-SW8 four dial codes are used to select a total of 16 files of microsteps. When the user sets the subdivision, electric motion should be stopped first. For detailed microstep subdivision settings, please see the drive panel description.
Output current setting	SW1-SW3 three dial switches are used to select a total of 8 output currents. For the specific output current setting, please see the driver panel description.
Pulse smoothing and ac/deceleration functions	Sw4 off: Does not enable the drive internal pulse smoothing function and drive the built-in 5ms position ac/deceleration Sw4 on: Enables drive internal pulse smoothing and drives built-in 5ms position ac/deceleration
Signal interface	PUL+ and PUL- are the positive and negative ends of the control pulse signal; DIR+ and DIR- are the positive and negative ends of the direction signal; ENA+ and ENA- are the positive and negative ends of the enable signal; PLC control only needs to connect +24V,PUL-,DIR-three lines
Motor interface	A+ and A- are connected to the positive and negative terminals of the A-phase winding of the stepping motor; B+ and B- are connected to the positive and negative terminals of the B-phase winding of the stepping motor. When A, B two-phase windings are exchanged, the motor can be in the opposite direction.
Power interface	Using DC power supply, the working voltage range is recommended 24-48VDC, voltage power greater than 60W. Pay attention to the polarity of the power supply V+,V- do not reverse.
LED	The driver has two indicators, red and green. The green light is the power indicator. The green light flashes after the driver is powered on. The red light is the fault indicator. The red light flickers when there is a fault in the gear and the encoder is misaligned. After the fault is cleared, the red light goes out. When an alarm occurs on the drive, it must be powered on again to clear the fault.
Installation Notes	Dimensions: 92.6 * 56 * 21mm, mounting hole spacing 87.5mm. Can be horizontal or vertical installation, advised to be vertical installation while it should be close to the metal cabinet for better cooling

Driver operating status LED indication

LED status	Drive status
● Green light	Drive is not enabled
●● Green flashing	The driver is working properly(Pulse flashing faster)
●●● 1green, 1red	Drive overcurrent
●●●● 1 green, 2 red	Driver input voltage overvoltage
●●●●● 1 green, 3 red	Drive internal voltage error

Driver cable diagram

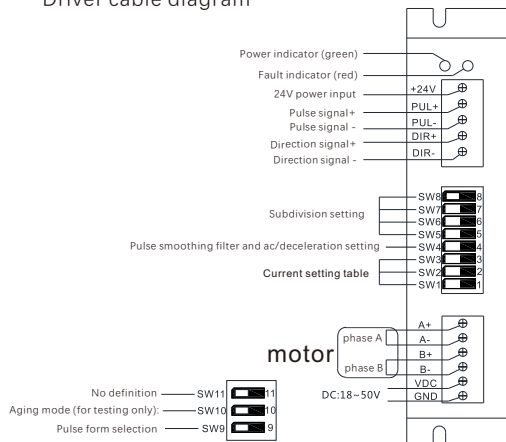

Operating current setting

Output current peak	Output current effective value	SW1	SW2	SW3
0.3A	0.2A	on	on	on
0.5A	0.3A	off	on	on
0.7A	0.5A	on	off	on
1.0A	0.7A	off	off	on
1.3A	1.0A	on	on	off
1.6A	1.2A	off	on	off
1.9A	1.4A	on	off	off
2.2A	1.6A	off	off	off

Microstep subdivision setting

Steps / Turn	SW5	SW6	SW7	SW8
200	on	on	on	on
400	off	on	on	on
800	on	off	on	on
1600	off	off	on	on
3200	on	on	off	on
6400	off	on	off	on
12800	on	off	off	on
25600	off	off	off	on
1000	on	on	on	off
2000	off	on	on	off
4000	on	off	on	off
5000	off	off	on	off
8000	on	on	off	off
10000	off	on	off	off
20000	on	off	off	off
25000	off	off	off	off

Special features introduction

Sw9: off: external pulse control, on: internal pulse automatic reversal

Sw10: off: pulse +direction, on: cw/ccw

57 60 stepping driver 2NS556C

Based on TI's new 32-bit multi-channel DSP processing chip platform, using internal PID current control algorithm design, with excellent performance. The built-in micro-segmentation technology and the automatic tuning function of the power-on parameter make the driver have the characteristics of low noise, low vibration, low heat and high-speed high-moment output, and can be well adapted to most applications of stepping motors.

- Pulse mode: single pulse/CW/CCW pulse
- Signal level: 5V-24V compatible
- Typical applications: stripping machine, marking machine, cutting machine, laser equipment, visual positioning, automatic equipment and so on. The application effect is particularly good in a device where the user desires high speed and small noise.

Installation size:

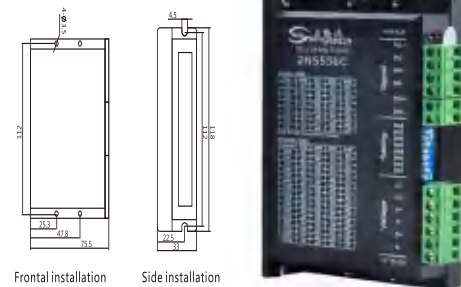

Drive function description

Drive function	Operating Instructions
Microstep subdivision setting	SW5-SW8 four dial codes are used to select a total of 16 files of microsteps. When the user sets the subdivision, electric motion should be stopped first. For detailed microstep subdivision settings, please see the drive panel description.
Output current setting	SW1-SW3 three dial switches are used to select a total of 8 output currents. For the specific output current setting, please see the driver panel description.
Automatic half-flow function	SW4 is used to set the automatic half-flow function of the driver, off means that the quiescent current is set to half of the working current, and on means that the quiescent current is the same as the working current. In general use, SW should be set to off, so that the heating of the motor and the driver is reduced, and the reliability is improved. The current is automatically halved about 0.4s after the pulse train stops.
Signal interface	PUL+ and PUL- are the positive and negative ends of the control pulse signal; DIR+ and DIR- are the positive and negative ends of the direction signal; ENA+ and ENA- are the positive and negative ends of the enable signal.
Motor interface	A+ and A- are connected to the positive and negative terminals of the A-phase winding of the stepping motor; B+ and B- are connected to the positive and negative terminals of the B-phase winding of the stepping motor. When A, B two-phase windings are exchanged, the motor can be in the opposite direction.
Power interface	It is powered by AC/AD power supply. The working voltage range is recommended to be AC20~40V or DC24~50V. The power supply is greater than 100W
LED	The driver has two indicators, red and green. The green light is the power indicator. The green light flashes after the driver is powered on. The red light is the fault indicator. The red light flickers when there is a fault in the gear and the encoder is misaligned. After the fault is cleared, the red light goes out. When an alarm occurs on the drive, it must be powered on again to clear the fault.
Installation Notes	Dimensions: 118 * 76 * 28mm, mounting hole spacing 112mm. Can be horizontal or vertical installation, advised to be vertical installation while it should be close to the metal cabinet for better cooling

Driver operating status LED indication

LED status	Drive status
● Green light	Drive is not enabled
●● Green flashing	The driver is working properly (Pulse flashing faster)
●● Green, ● Red	Drive overcurrent
●● Green, ●● Red	Driver input voltage overvoltage
●● Green, ●●● Red	Drive internal voltage error

Driver cable diagram

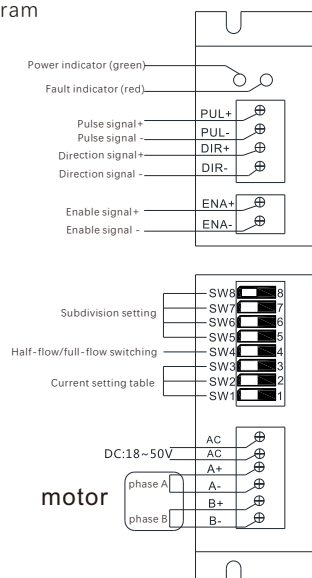

Operating current setting

Output current peak	Output current effective value	SW1	SW2	SW3
1.4A	1.0A	on	on	on
2.1A	1.5A	off	on	on
2.7A	1.9A	on	off	on
3.2A	2.3A	off	off	on
3.8A	2.7A	on	on	off
4.3A	3.1A	off	on	off
4.9A	3.5A	on	off	off
5.6A	4.0A	off	off	off

Microstep subdivision setting

Steps / Turn	SW5	SW6	SW7	SW8
400	on	on	on	on
800	off	on	on	on
1600	on	off	on	on
3200	off	off	on	on
6400	on	on	off	on
12800	off	on	off	on
25600	on	off	off	on
51200	off	off	off	on
1000	on	on	on	off
2000	off	on	on	off
4000	on	off	on	off
5000	off	off	on	off
8000	on	on	off	off
10000	off	on	off	off
20000	on	off	off	off
40000	off	off	off	off

57 60 Stepping driver 2NS556A

Based on 32-bit ARM processing chip platform, using internal PID current control algorithm design, with excellent performance. The built-in micro-segmentation technology and the automatic tuning function of the power-on parameter make the driver have the characteristics of low noise, low vibration, low heat and high-speed high-moment output, and can be well adapted to most applications of stepping motors.

- Pulse mode: single pulse/CW/CCW pulse
- Signal level: 5V/24V separate wiring, simple and practical, strong anti-interference ability.
- Typical applications: stripping machine, marking machine, cutting machine, laser equipment, visual positioning, automatic equipment and so on. The application effect is particularly good in a device where the user desires high speed and small noise.

Installation size:

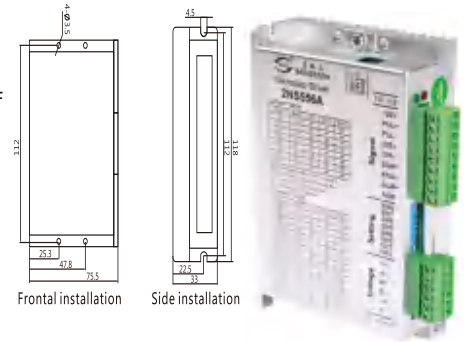

Drive function description

Drive function	Operating Instructions
Microstep subdivision setting	SW5-SW8 four dial codes are used to select a total of 16 files of microsteps. When the user sets the subdivision, electric motion should be stopped first. For detailed microstep subdivision settings, please see the drive panel description.
Output current setting	SW1-SW3 three dial switches are used to select a total of 8 output currents. For the specific output current setting, please see the driver panel description.
Pulse smoothing and ac/deceleration functions	Sw4 off: Does not enable the drive internal pulse smoothing function and drive the built-in 5ms position ac/deceleration Sw4 on: Enables drive internal pulse smoothing and drives built-in 5ms position ac/deceleration
Signal interface	PUL+ and PUL- are the positive and negative ends of the control pulse signal; DIR+ and DIR- are the positive and negative ends of the direction signal; ENA+ and ENA- are the positive and negative ends of the enable signal; ALM+, ALM- are the positive and negative ends of the alarm. PLC control only needs to connect +24V, pul- DIR- three wires.
Motor interface	A+ and A- are connected to the positive and negative terminals of the A-phase winding of the stepping motor; B+ and B- are connected to the positive and negative terminals of the B-phase winding of the stepping motor. When A, B two-phase windings are exchanged, the motor can be in the opposite direction.
Power interface	Using DC power supply, the working voltage range is recommended 24-50VDC, voltage power greater than 100W. Pay attention to the polarity of the power supply V+, V- do not reverse
LED	The driver has two indicators, red and green. The green light is the power indicator. The green light flashes after the driver is powered on. The red light is the fault indicator. The red light flickers when there is a fault in the gear and the encoder is misaligned. After the fault is cleared, the red light goes out. When an alarm occurs on the drive, it must be powered on again to clear the fault.
Installation Notes	Dimensions: 118*75.5*33mm, mounting hole spacing 112mm. Can be horizontal or vertical installation, advised to be vertical installation while it should be close to the metal cabinet for better cooling

Driver operating status LED indication

LED status	Drive status
● Green light	Drive is not enabled
●● Green flashing	The driver is working properly(Pulse flashing faster)
●● Green, ● Red	Drive overcurrent
●● Green, ●● Red	Driver input voltage overvoltage
●● Green, ●●● Red	Drive internal voltage error

Driver cable diagram

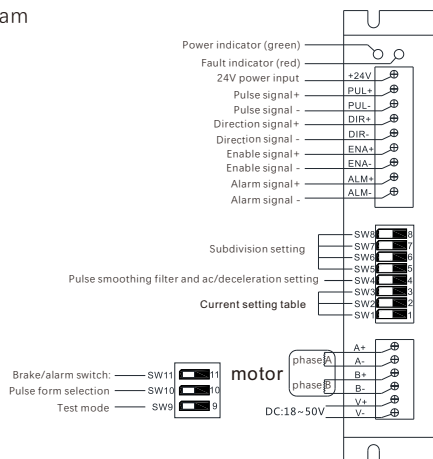

Operating current setting

Output current peak	Output current effective value	SW1	SW2	SW3
1.4A	1.0A	on	on	on
2.1A	1.5A	off	on	on
2.7A	1.9A	on	off	on
3.2A	2.3A	off	off	on
3.8A	2.7A	on	on	off
4.3A	3.1A	off	on	off
4.9A	3.5A	on	off	off
5.6A	4.0A	off	off	off

Microstep subdivision setting

Steps / Turn	SW5	SW6	SW7	SW8
400	on	on	on	on
800	off	on	on	on
1600	on	off	on	on
3200	off	off	on	on
6400	on	on	off	on
12800	off	on	off	on
25600	on	off	off	on
51200	off	off	off	on
1000	on	on	on	off
2000	off	on	on	off
4000	on	off	on	off
5000	off	off	on	off
8000	on	on	off	off
10000	off	on	off	off
20000	on	off	off	off
40000	off	off	off	off

Special function introduction

- Sw9: off: external pulse control, on: internal pulse automatic reversal
- SW10: off pulse + direction on: double pulse cw/ccw
- SW11: off: The ALM port is the alarm output, and the on:ALM port is the brake output function.

86 Stepping driver 2NS860H

Based on 32-bit ARM processing chip platform, using internal PID current control algorithm design, with excellent performance. The built-in micro-segmentation technology and the automatic tuning function of the power-on parameter make the driver have the characteristics of low noise, low vibration, low heat and high-speed high-moment output, and can be well adapted to most applications of stepping motors.

- Pulse mode: single pulse/CW/CCW pulse
- Signal level: 5V/24V separate wiring, simple and practical, strong anti-interference ability.
- Typical applications: stripping machine, marking machine, cutting machine, laser equipment, visual positioning, automatic equipment and so on. The application effect is particularly good in a device where the user desires high speed and small noise.

Installation size:

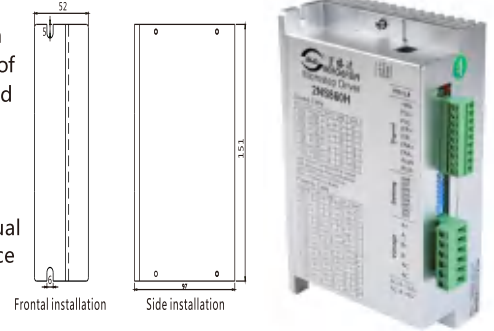

Drive function description

Drive function	Operating Instructions
Microstep subdivision setting	SW5-SW8 four dial codes are used to select a total of 16 files of microsteps. When the user sets the subdivision, electric motion should be stopped first. For detailed microstep subdivision settings, please see the drive panel description.
Output current setting	SW1-SW3 three dial switches are used to select a total of 8 output currents. For the specific output current setting, please see the driver panel description.
Pulse smoothing and ac/deceleration functions	Sw4 off: Does not enable the drive internal pulse smoothing function and drive the built-in 5ms position ac/deceleration Sw4 on: Enables drive internal pulse smoothing and drives built-in 5ms position ac/deceleration
Signal interface	PUL+ and PUL- are the positive and negative ends of the control pulse signal; DIR+ and DIR- are the positive and negative ends of the direction signal; ENA+ and ENA- are the positive and negative ends of the enable signal; ALM+, ALM- are the positive and negative ends of the alarm. PLC control only needs to connect +24V, pul- DIR- three wires.
Motor interface	A+ and A- are connected to the positive and negative terminals of the A-phase winding of the stepping motor; B+ and B- are connected to the positive and negative terminals of the B-phase winding of the stepping motor. When A, B two-phase windings are exchanged, the motor can be in the opposite direction.
Power interface	Power supply AC and DC universal, the working voltage range is recommended to 24-100V or AC 20-80V, voltage power greater than 200W.
LED	The driver has two indicators, red and green. The green light is the power indicator. The green light flashes after the driver is powered on. The red light is the fault indicator. The red light flickers when there is a fault in the gear and the encoder is misaligned. After the fault is cleared, the red light goes out. When an alarm occurs on the drive, it must be powered on again to clear the fault.
Installation Notes	Dimensions: 151 * 97 * 52mm, mounting hole spacing 142. installation should be close to the metal cabinet for better cooling

Driver operating status LED indication

LED status	Drive status
● Green light	Drive is not enabled
●● Green flashing	The driver is working properly(Pulse flashing faster)
●●● 1green, 1red	Drive overcurrent
●●●● 1 green, 2 red	Driver input voltage overvoltage
●●●●● 1 green, 3 red	Drive internal voltage error

Driver cable diagram

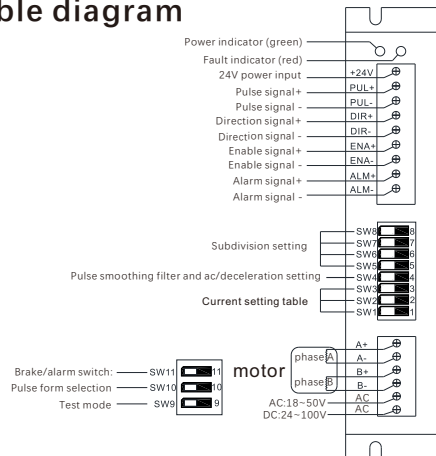

Special function introduction

- Sw9: off: external pulse control, on: internal pulse automatic reversal
- SW10: off pulse + direction on: double pulse cw/ccw
- SW11: off: The ALM port is the alarm output, and the on:ALM port is the brake output function.

Operating current setting

Output current peak	Output current effective value	SW1	SW2	SW3
2.40A	2.00A	on	on	on
3.08A	2.57A	off	on	on
3.77A	3.14A	on	off	on
4.45A	3.71A	off	off	on
5.14A	4.28A	on	on	off
5.83A	4.86A	off	on	off
6.52A	5.43A	on	off	off
7.20A	6.00A	off	off	off

Microstep subdivision setting

Steps / Turn	SW5	SW6	SW7	SW8
400	on	on	on	on
800	off	on	on	on
1600	on	off	on	on
3200	off	off	on	on
6400	on	on	off	on
12800	off	on	off	on
25600	on	off	off	on
51200	off	off	off	on
1000	on	on	on	off
2000	off	on	on	off
4000	on	off	on	off
5000	off	off	on	off
8000	on	on	off	off
10000	off	on	off	off
20000	on	off	off	off
40000	off	off	off	off

86 stepping driver 3NS2250

Installation size:

Based on ARM's new 32-bit DSP processing chip platform, the internal PID current control algorithm design, with excellent performance. The built-in micro-segmentation technology and the automatic tuning function of the power-on parameter make the driver have the characteristics of low noise, low vibration, low heat generation and high-speed high torque output. In addition, the patented three-phase demodulation algorithm can give full play to the low-speed resonance and small torque ripple characteristics of the phase stepping motor, and can be well adapted to applications requiring higher stability.

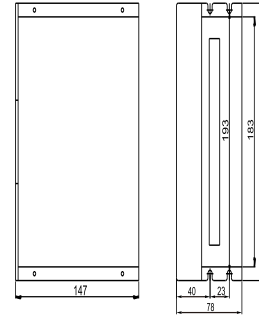

- Pulse mode: single pulse/ CW/CCW pulse
- Signal level: 5V/24V separate wiring, simple and practical, strong anti-interference ability
- Typical applications: potting machines, engraving machines, cutting machines, laser equipment, CNC machine tools, automatic equipment and so on. The application effect is particularly good in a device where the user desires high speed and small noise.

Drive function description

Drive function	Operating Instructions
Microstep subdivision setting	SW5-SW8 four dial codes are used to select a total of 16 files of microsteps. When the user sets the subdivision, electric motion should be stopped first. For detailed microstep subdivision settings, please see the drive panel description.
Output current setting	SW1-SW3 three dial switches are used to select a total of 8 output currents. For the specific output current setting, please see the driver panel description.
Pulse smoothing filter	The SW4 dial code is used to select the pulse smoothing function of the drive, the off means the off function, and on means the function is turned on
Pulse form selection	SW9 dial code is used to select the pulse form, OFF: pulse + direction ON: CW/CCW
Signal interface	PUL+ and PUL- are the positive and negative ends of the control pulse signal; DIR+ and DIR- are the positive and negative ends of the direction signal; ENA+ and ENA- are the positive and negative ends of the enable signal; ALM+ and ALM- are the positive and negative terminals of the alarm output signal; PLC control only needs to connect +24V, PUL-, DIR-, three lines
Motor interface	U, V, W corresponds the motor windings U, V, W, Arbitrarily swapping two of the three winding wires can change the direction of the motor., PE ground wire.
Power interface	The working voltage range is recommended for AC 110-230V. It is recommended to add a filter (EMI FILTER) before the power supply circuit.
LED	The driver has two indicators, red and green. The green light is the power indicator. The green light flashes after the driver is powered on. The red light is the fault indicator. The red light flickers when there is a fault in the gear and the encoder is misaligned. After the fault is cleared, the red light goes out. When an alarm occurs on the drive, it must be powered on again to clear the fault.
Installation Notes	Dimensions: 183*144*48 mm, mounting hole spacing 156. installation should be close to the metal cabinet for better cooling

Driver operating status LED indication

LED status	Drive status
●● Green flashing	The driver is working properly (pulse input flashes faster)
●● 1 green, 1 red	Drive overcurrent
●●● 1 green, 2 red	The code wheel is reversed or there is no code dial (you can change the parameter NO.15)
●●●● 1 green, 3 red	Position error (closed loop)
●●●●● 1 green, 4 red	IPM Alarm
●●●●●● 1 green, 5 red	ADC hardware error

Driver cable diagram

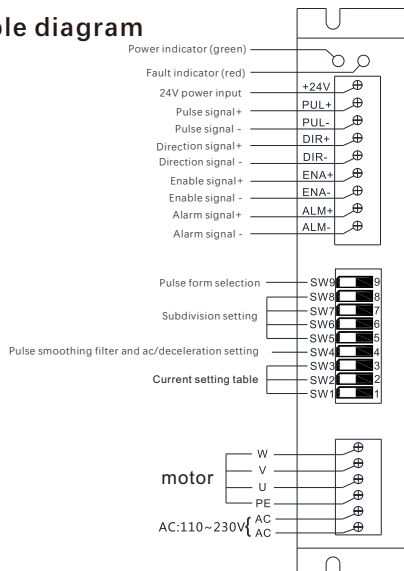

Operating current setting

Output current peak	Output current Rms	SW1	SW2	SW3
8.4A	depend by Pa5 parameter	on	on	on
3.0A	2.0A	off	on	on
3.5A	2.5A	on	off	on
4.2A	3.0A	off	off	on
4.8A	3.5A	on	on	off
5.2A	4.0A	off	on	off
6.1A	4.5A	on	off	off
6.6A	5.0A	off	off	off

Microstep subdivision setting

Steps / Turn	SW5	SW6	SW7	SW8
200	on	on	on	on
400	off	on	on	on
600	on	off	on	on
800	off	off	on	on
1000	on	on	off	on
1200	off	on	off	on
2000	on	off	off	on
3000	off	off	off	on
4000	on	on	on	off
5000	off	on	on	off
6000	on	off	on	off
10000	off	off	on	off
12000	on	on	off	off
20000	off	on	off	off
30000	on	off	off	off
8000	off	off	off	off

110 130 stepping driver 3NS2280

Installation size:

Based on ARM's new 32-bit DSP processing chip platform, the internal PID current control algorithm design, with excellent performance. The built-in micro-segmentation technology and the automatic tuning function of the power-on parameter make the driver have the characteristics of low noise, low vibration, low heat generation and high-speed high torque output. In addition, the patented three-phase demodulation algorithm can give full play to the low-speed resonance and small torque ripple characteristics of the phase stepping motor, and can be well adapted to applications requiring higher stability.

- Pulse mode: single pulse/ CW/CCW pulse
- Signal level: 5V/24V separate wiring, simple and practical, strong anti-interference ability
- Typical applications: potting machines, engraving machines, cutting machines, laser equipment, CNC machine tools, automatic equipment and so on. The application effect is particularly good in a device where the user desires high speed and small noise.

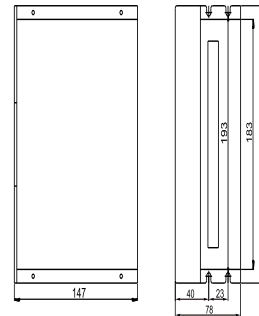

Drive function description

Drive function	Operating Instructions
Microstep subdivision setting	SW5-SW8 four dial codes are used to select a total of 16 files of microsteps. When the user sets the subdivision, electric motion should be stopped first. For detailed microstep subdivision settings, please see the drive panel description.
Output current setting	SW1-SW3 three dial switches are used to select a total of 8 output currents. For the specific output current setting, please see the driver panel description.
Pulse smoothing filter	The SW4 dial code is used to select the pulse smoothing function of the drive, the off means the off function, and on means the function is turned on
Pulse form selection	SW9 dial code is used to select the pulse form, OFF: pulse + direction ON: CW/CCW
Signal interface	PUL+ and PUL- are the positive and negative ends of the control pulse signal; DIR+ and DIR- are the positive and negative ends of the direction signal; ENA+ and ENA- are the positive and negative ends of the enable signal; ALM+ and ALM- are the positive and negative terminals of the alarm output signal; PLC control only needs to connect +24V, PUL-, DIR-, three lines
Motor interface	U, V, W corresponds the motor windings U, V, W, Arbitrarily swapping two of the three winding wires can change the direction of the motor., PE ground wire.
Power interface	The working voltage range is recommended for AC 110-230V. It is recommended to add a filter (EMI FILTER) before the power supply circuit.
LED	The driver has two indicators, red and green. The green light is the power indicator. The green light flashes after the driver is powered on. The red light is the fault indicator. The red light flickers when there is a fault in the gear and the encoder is misaligned. After the fault is cleared, the red light goes out. When an alarm occurs on the drive, it must be powered on again to clear the fault.
Installation Notes	Dimensions: 183*144*48 mm, mounting hole spacing 156. installation should be close to the metal cabinet for better cooling

Driver operating status LED indication

LED status	Drive status
●● Green flashing	The driver is working properly (pulse input flashes faster)
●● 1 green, 1 red	Drive overcurrent
●●● 1 green, 2 red	The code wheel is reversed or there is no code dial (you can change the parameter NO.15)
●●●● 1 green, 3 red	Position error (closed loop)
●●●●● 1 green, 4 red	IPM Alarm
●●●●●● 1 green, 5 red	ADC hardware error

Driver cable diagram

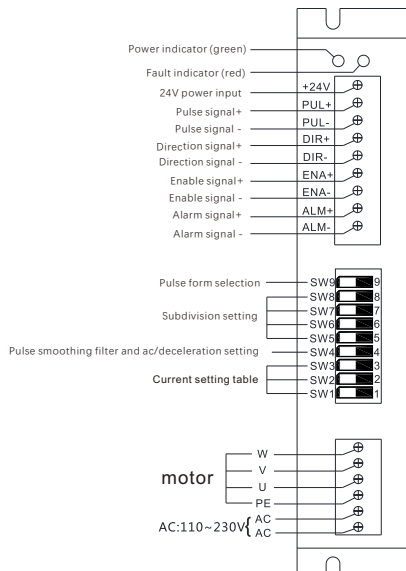

Operating current setting

Output current peak	Output current Rms	SW1	SW2	SW3
3.9A	depend by Pa5 parameter	on	on	on
5.0A	3.6A	off	on	on
6.3A	4.5A	on	off	on
7.6A	5.4A	off	off	on
8.7A	6.2A	on	on	off
9.8A	7.0A	off	on	off
11.2A	8.0A	on	off	off
12.6A	9.0A	off	off	off

Microstep subdivision setting

Steps / Turn	SW5	SW6	SW7	SW8
200	on	on	on	on
400	off	on	on	on
600	on	off	on	on
800	off	off	on	on
1000	on	on	off	on
1200	off	on	off	on
2000	on	off	off	on
3000	off	off	off	on
4000	on	on	on	off
5000	off	on	on	off
6000	on	off	on	off
10000	off	off	on	off
12000	on	on	off	off
20000	off	on	off	off
30000	on	off	off	off
8000	off	off	off	off

110 130 stepping driver 3NS2280

Parameter list

No.	Definition	Function	Default
1	Light load current ratio	Minimum current and maximum current percentage (closed loop use)	50%
2	Input signal logic negation	Input (enable) negation	0
3	Output signal logic negation	Output negation	0
4	Motor action time after enable	0: Run after 0.5 seconds after enable 1: Run directly after enable	1
5	Rated current of motor operation	When the current selection switches SW1, SW2, and SW3 are all ON, the rated current of the drive runs according to the value set by this parameter, and the value is the effective value. Unit*0.01A	276
6	Positioning completion range setting	Position deviation is lower than this set value and output positioning completion signal	20
7	Encoder line	Requires an integer multiple of 50 after 4 octave	1000
8	Position out-of-tolerance alarm setting	When the position deviation is higher than the set value, the drive output position out of tolerance alarm	4000
9	Pulse command smoothing Filtering	When the input pulse frequency is low, set it larger to make the motor run more smoothly. Use parameter data when SW4 is ON	20
10	Current proportional gain	The larger the setting, the higher the gain, and the smaller the current tracking error. However, if the gain is too large, oscillation or noise will occur.	140
11	Current proportional integral	The smaller the setting, the faster the integration speed and the smaller the current tracking error.	100
12	Position Ac/deceleration coefficient	When SW4 is ON, 0: No ac/deceleration. For other values, the smaller the value, the shorter the acceleration/deceleration time.	80
13	Half wave function	Turn on half wave function (for open loop) 0: full flow 1: half flow	1
15	Motor power line phase modulation	After motor power phase adjustment, normal control can be achieved without changing the phase sequence of the encoder.	0
16	Closed-loop control compensation		245
17	Invert position command	0: Normal; 1: Reverse direction	0
18	Test run	0: external pulse; 1: automatic operation	0
19	open-loop control compensation		400
20	alarm record0	Last alarm record	0
21	alarm record1	The penultimate alarm record	0
...
27	alarm record 7	Eighth to last alarm record	0
28~29	System use	Reserved for factory use	
30	Drive version	Reserved for factory use	108

Show interface:

No.	content	Definition
1	r	Speed
2	i	Current
3	c	Instruction position
4	E	Encoder position
6	d	5 positions lower
7	d .	High position deviation
8	IO	Port information (from right to left are enable, direction, pulse, blank, alarm)
9	EE-OP	Press Enter to restore the default value, it takes a while
10	PA	Display and modify various parameters

42 series two-phase stepping motor

General specifications

Step accuracy	±5% (Whole step, Empty load)
Temperature rise	80 °C Max
Ambient temperature	-10 °C — +50 °C
Insulation resistance	100MΩmin. 500VDC
Pressure resistance	500VAC for one minute
Radial runout	0.06 Max. (450g-load)
Axial runout	0.08 Max. (450g-load)



Technical specifications

Model	Phase	Step angle (°)	Holding torque N.M	Rated current A	Phase inductance mH	Phase resistance Ohm	Number of leads	Rotor inertia (g.cm ²)	Shaft diameter mm	Motor weight Kg	Body length L(mm)	Axis length L1(mm)
35BG26	2	1.8	0.07	0.4	16	35	4	12	5	0.14	26	20
39BG34	2	1.8	0.22	0.6	16	15	4	20	5	0.2	34	20
42BG40	2	1.8	0.22	1.2	5.5	2.5	4	57	5	0.24	40	24
42BG48	2	1.8	0.42	1.5	5.0	2.6	4	82	5	0.34	48	24
42BG60	2	1.8	0.72	2.0	4.8	2.0	4	114	5	0.5	60	24

Dimensions(mm)

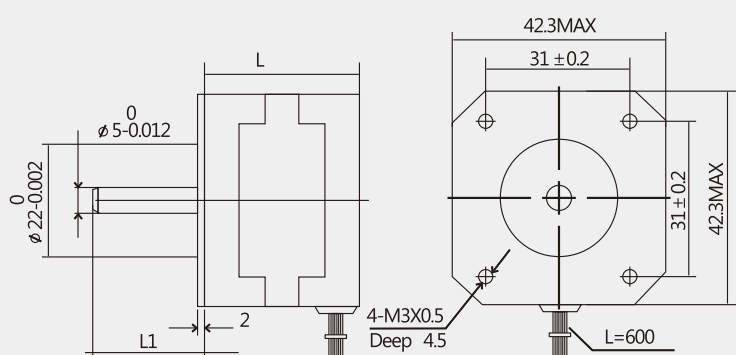

Lead connection

connection	Driver wiring	Corresponding motor leads	Applications
Tandem	A+	A	Low speed
	A-	C	
	B+	B	
	B-	D	
	Vacant	$\bar{A}\bar{C}$ connect	
in parallel	Vacant	$\bar{B}\bar{D}$ connect	high speed
	A+	$A\bar{C}$	
	A-	$\bar{A}C$	
	B+	$B\bar{D}$	
	B-	$\bar{B}D$	

Wiring diagram

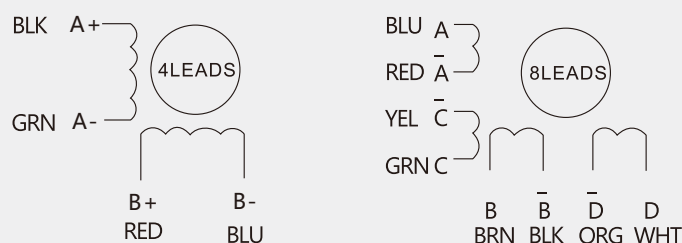

57/60 series two-phase stepping motor

General specifications

Step accuracy	±5% (Whole step, Empty load)
Temperature rise	80 °C Max
Ambient temperature	-10 °C — +50 °C
Insulation resistance	100MΩmin. 500VDC
Pressure resistance	500VAC for one minute
Radial runout	0.06 Max. (450g-load)
Axial runout	0.08 Max. (450g-load)



Technical specifications

Model	Phase	Step angle (°)	Holding torque N.M	Rated current A	Phase inductance mH	Phase resistance Ohm	Number of leads	Rotor inertia (g.cm ²)	Shaft diameter mm	Motor weight Kg	Body length L(mm)
57BG55	2	1.8	1.2	3.0	1.2	0.8	4	260	6.35/8	0.6	55
57BG76	2	1.8	2.0	4.0	2.1	1.0	4	460	8	1.0	76
57BG84	2	1.8	2.2	4.0	1.8	0.8	4	460	8	1.1	84
57BG112	2	1.8	2.8	4.0	3.2	0.78	4	720	8	1.4	112
60BG56	2	1.8	1.5	4.0	1.1	0.44	4	340	8	0.8	56
60BG86	2	1.8	3.0	4.0	2.62	0.75	4	690	8	1.3	86

Dimensions

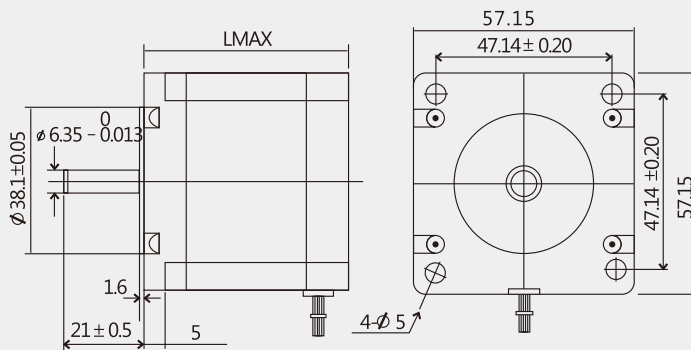

* The above is only the representative product 57BG84 motor shaft diameter is 8mm with a platform
When the brake is required to be added, the motor length will increase by 40 mm.

Wiring diagram

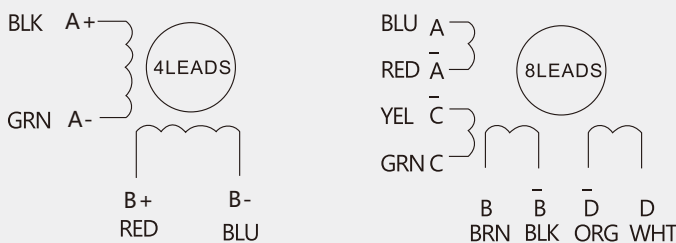

Lead connection

connection	Driver wiring	Corresponding motor leads	Applications
Tandem	A+	A	Low speed
	A-	C	
	B+	B	
	B-	D	
	Vacant	$\bar{A}\bar{C}$ connect	
in parallel	Vacant	$\bar{B}\bar{D}$ connect	high speed
	A+	$A\bar{C}$	
	A-	$\bar{A}C$	
	B+	$B\bar{D}$	
	B-	$\bar{B}D$	

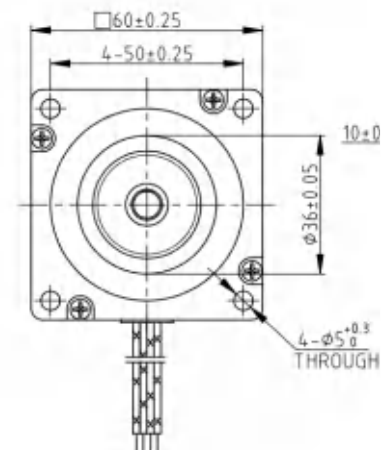

86 series two-phase stepping motor



General specifications

Step accuracy	±5% (Whole step, Empty load)
Temperature rise	80 °C Max
Ambient temperature	-10 °C — +50 °C
Insulation resistance	100MΩmin. 500VDC
Pressure resistance	500VAC for one minute
Radial runout	0.06 Max. (450g-load)
Axial runout	0.08 Max. (450g-load)

Technical specifications

Model	Phase	Step angle (°)	Holding torque N.M	Rated current A	Phase inductance mH	Phase resistance Ohm	Number of leads	Rotor inertia g.cm ²	Positioning torque kg.cm	Motor weight Kg	Body length L(mm)
86BG65	2	1.8	3.5	2.8	3.9	1.4	4	800	0.8	2	65
86BG80	2	1.8	4.5	4.2	3.5	0.8	4	1400	1.3	2.3	80
86BG118	2	1.8	8.5	4.9	5.2	0.95	4	2800	2.5	3.8	118
86BG156	2	1.8	12	4.9	8.7	1.4	4	4000	3.8	5.4	156

Dimensions

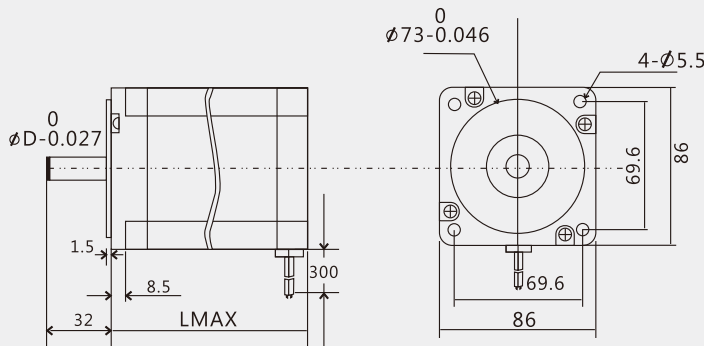

When the brake is required to be added, the motor length will increase by 40 mm.

Wiring diagram

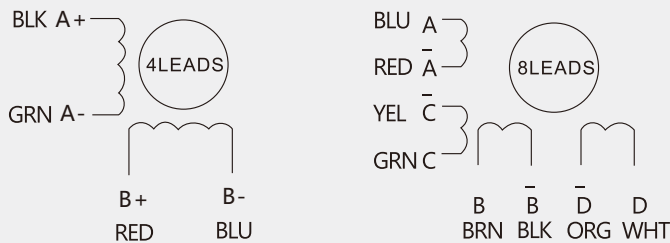

Lead connection

connection	Driver wiring	Corresponding motor leads	Applications
Tandem	A+	A	Low speed
	A-	C	
	B+	B	
	B-	D	
	Vacant	\overline{AC} connect	
in parallel	Vacant	\overline{BD} connect	high speed
	A+	\overline{AC}	
	A-	\overline{AC}	
	B+	\overline{BD}	
	B-	\overline{BD}	

Motor shaft detailed parameters

	T	KEY	D
86BG65	/	/	12.7
86BG80	/	/	14
86BG118	16.59	5*5*25	14
86BG156	16	5*5*25	14

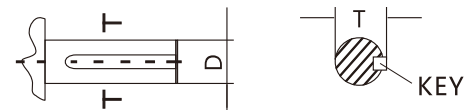

With key shaft diameter size

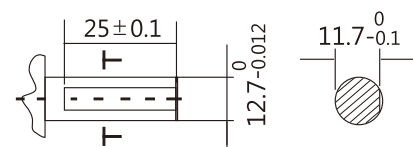

86A4 shaft size

86 series three-phase stepping motor

General specifications

Step accuracy	±5% (Whole step, Empty load)
Temperature rise	80 °C Max
Ambient temperature	-10 °C — +50 °C
Insulation resistance	100MΩmin. 500VDC
Pressure resistance	500VAC for one minute
Radial runout	0.06 Max. (450g-load)
Axial runout	0.08 Max. (450g-load)



Technical specifications

Model	Phase	Step angle (°)	Holding torque N.M	Rated current A	Phase inductance mH	Phase resistance Ohm	Number of leads	Rotor inertia kg.cm ²	Shaft diameter mm	Motor weight Kg	Body length L(mm)
3H86BG100	3	1.2	4.0	2.0	14.6	4.65	3	2400	12	2.8	97
3H86BG130	3	1.2	6.0	3.0	8.0	2.0	3	3480	14	3.8	125
3H86BG150	3	1.2	8.5	3.2	9.57	2.6	3	4560	14	4.7	145

Dimensions

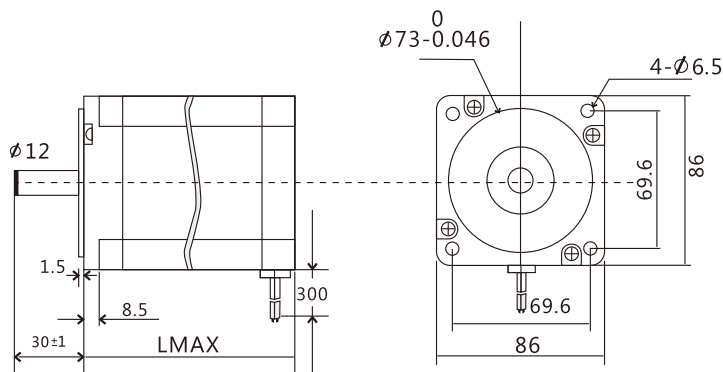

Shaft key (mm)

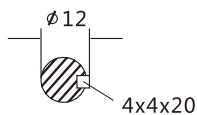

Note: When the brake needs to be added, the length of the motor will increase by 40mm

Wiring diagram

Driver wiring	Corresponding motor leads
U	1
V	2
W	3
PE	4

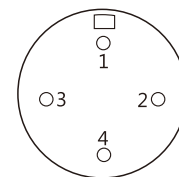

Wiring diagram

Driver wiring	Corresponding motor leads
U	U
V	V
W	W
PE	PE

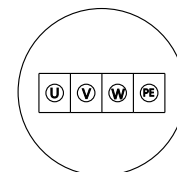

Motor rear cover wiring diagram

110/130 series three-phase stepping motor

General specifications

Step accuracy	±5% (Whole step, Empty load)
Temperature rise	80 °C Max
Ambient temperature	-10 °C — +50 °C
Insulation resistance	100MΩmin. 500VDC
Pressure resistance	500VAC for one minute
Radial runout	0.06 Max. (450g-load)
Axial runout	0.08 Max. (450g-load)



Technical specifications

Model	Phase	Step angle (°)	Holding torque N.M	Rated current A	Phase inductance mH	Phase resistance Ohm	Number of leads	Rotor inertia kg.cm ²	Shaft diameter mm	Motor weight Kg	Body length L(mm)
3H110BG135	3	1.2	8	4.3	11.9	1.00	3	8.6	19	5.5	135
3H110BG160	3	1.2	12	5.8	11.5	0.76	3	11.9	19	7.1	160
3H110BG185	3	1.2	16	6.0	19.0	1.28	3	13.6	19	8.8	185
3H110BG220	3	1.2	20	6.8	22.0	1.24	3	17.4	19	11	219
3H130BG220	3	1.2	28	6.8	11.0	1.10	3	25.0	24	17	220
3H130BG250	3	1.2	35	6.8	13.1	1.30	3	35.0	24	19	252
3H130BG280	3	1.2	50	6.8	18.0	1.70	3	45.5	24	20.5	281

Dimensions

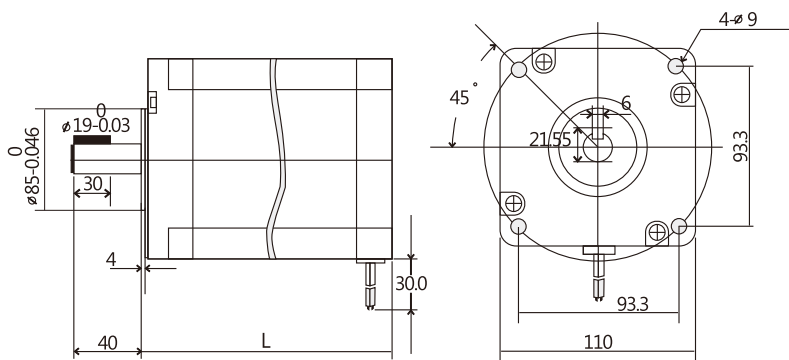

Dimensions

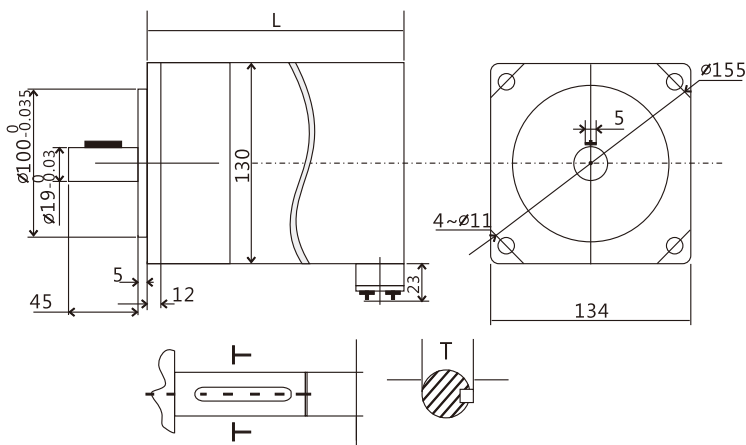

T = 21
KEY=5×5×30

Wiring diagram

Driver wiring	Corresponding motor leads
U	1
V	2
W	3
PE	4

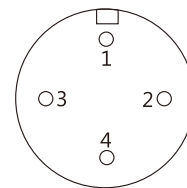

Wiring diagram

Driver wiring	Corresponding motor leads
U	U
V	V
W	W
PE	PE

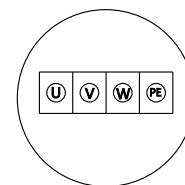

Motor rear cover wiring diagram

Bergerda stepping motor torque curve

42 Series two-phase stepping motor torque curve

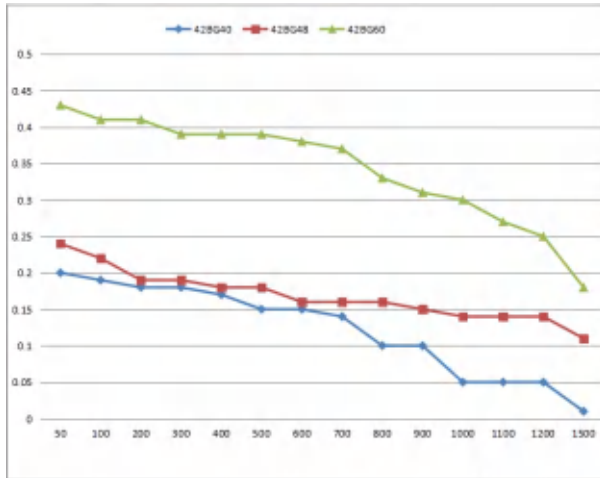

Drive : 2NS422
Voltage : 24V DC
Current : Rated
Micro step : 1600

57 Series two-phase stepping motor torque curve

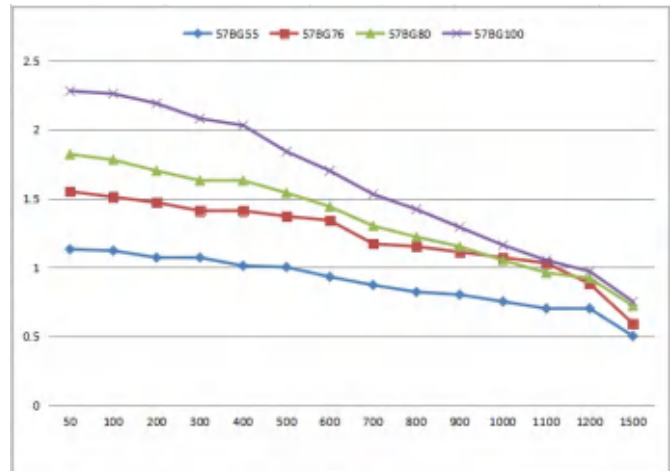

Drive : 2NS556A
Voltage : 36V DC
Current : Rated
Micro step : 1600

60 Series two-phase stepping motor torque curve

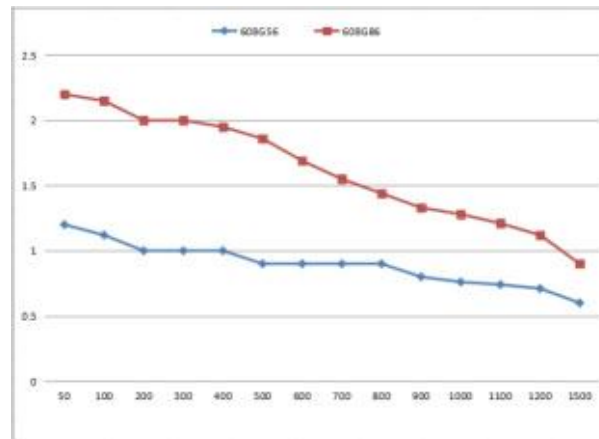

Drive : 2NS556A
Voltage : 36V DC
Current : Rated
Micro step : 1600

86 Series two-phase stepping motor torque curve

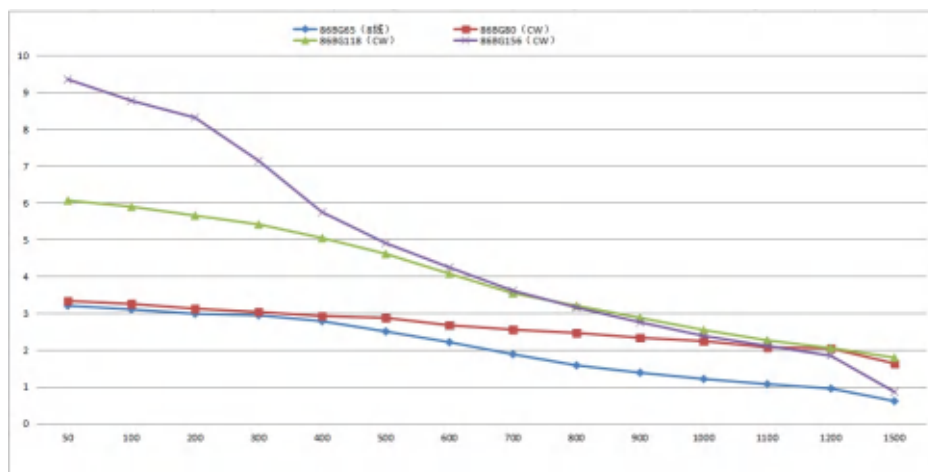

Drive : 2NS860H
Voltage : 60V AC
Current : Rated
Micro step : 1600

Bergerda stepping motor torque curve

42Series two-phase closed loop stepping motor torque curve

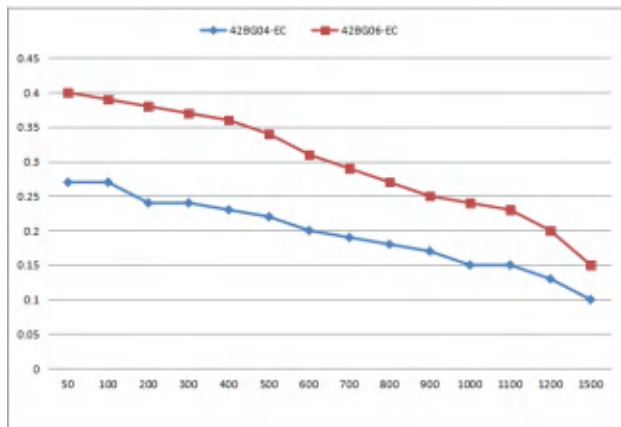

Drive: 2LS556A-42 Current: Rated
 Voltage: 24VDC Subdivision: 1600

57Series two-phase closed loop stepping motor torque curve

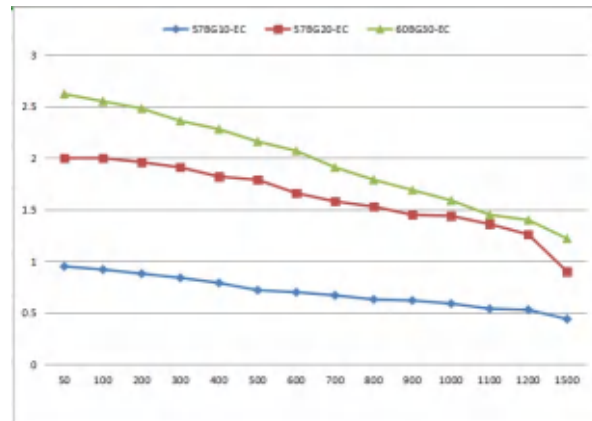

Drive: 2LS556A Current: Rated
 Voltage: 36VDC Subdivision: 1600

86Series two-phase closed loop stepping motor torque curve

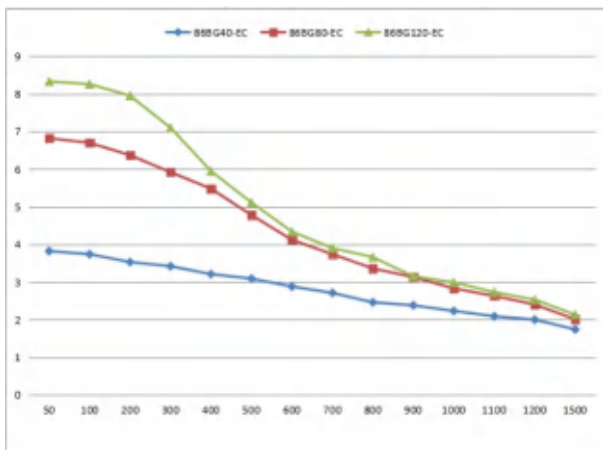

Drive: 2LS860H Current: Rated
 Voltage: 60VAC Subdivision: 1600

110Series two-phase closed loop stepping motor torque curve

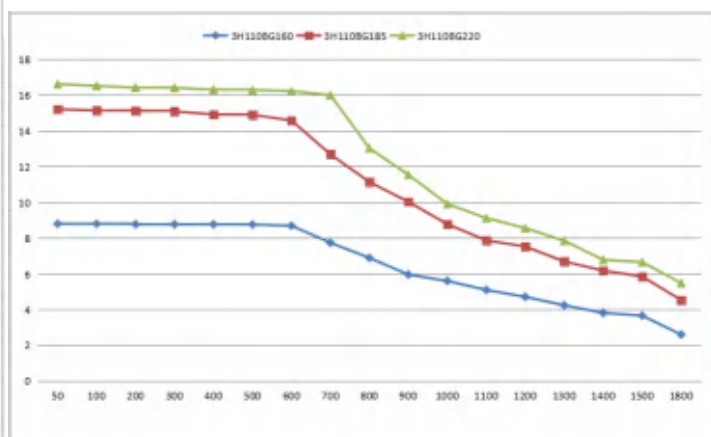

Drive: 3NS2280 Current: Rated
 Voltage: 220VAC Subdivision: 1600

IO controlled stepping driver

In the automation equipment, transportation, transmission, connection and other functions are often used. Originally used more traditional speed motor. Stepping with the IO speed control now is more cost effective.
 Features: Internal automatic operation in speed control mode, IO control starts and stops, dial code selects running speed, and has two trigger modes. Mode 2 is compatible with the inverter IO mode, IN1 is forward and IN2 is reversed. The states of IN1 and IN2 are the same and stop not turning.

Performance comparison	IO stepping	Ordinary speed control motor
Speed accuracy	Stable speed	Large fluctuation
Start and stop effect	S-shaped ac/deceleration, start and stop smoothly	Start and stop jitter
noise	Low noise	loud noise
Self-locking force	Self-locking force	Unstable state

Order specification table:

Drive Model	Peak current	input voltage range	Install dimensions	weight	matched motor
2NS556-IO	5.6	24-50VDC	118x76x33	300g	57、60
2NS860-IO	7.2	24-80VAC	151x97x52	590g	86
3NS2280-IO	12.6	110-240VAC	203x147x78	1345g	3phase 110, 130

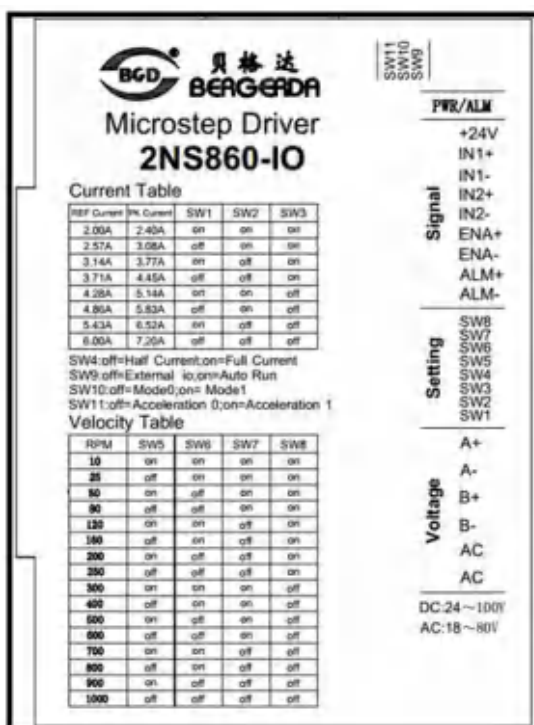

Microstep Driver 2NS860-IO

Current Table

REF Current	% Current	SW1	SW2	SW3
2.00A	2.40A	on	on	on
2.57A	3.08A	off	on	on
3.14A	3.77A	on	on	on
3.71A	4.45A	off	off	on
4.28A	5.14A	on	on	off
4.85A	5.83A	off	on	off
5.43A	6.52A	on	off	off
6.00A	7.20A	off	off	off

SW4:off=Half Current,on=Full Current
 SW9:off=External io,on=Auto Run
 SW10:off=Mode0,on= Mode1
 SW11:off=Acceleration 0,on=Acceleration 1

Velocity Table

RPM	SW5	SW6	SW7	SW8
10	on	on	on	on
25	off	on	on	on
50	on	off	on	on
90	off	off	on	on
135	on	on	off	on
180	off	on	off	on
200	on	on	off	on
250	off	off	off	on
300	on	on	on	off
400	off	on	on	off
500	on	off	on	off
600	off	off	on	off
700	on	on	off	off
800	off	on	off	off
900	on	off	off	off
1000	off	off	off	off

Signal
 PWR/ALM
 +24V
 IN1+
 IN1-
 IN2+
 IN2-
 ENA+
 ENA-
 ALM+
 ALM-

Setting
 SW8
 SW7
 SW6
 SW5
 SW4
 SW3
 SW2
 SW1

Voltage
 A+
 A-
 B+
 B-
 AC
 AC

DC:24~100V
 AC:1B~80V

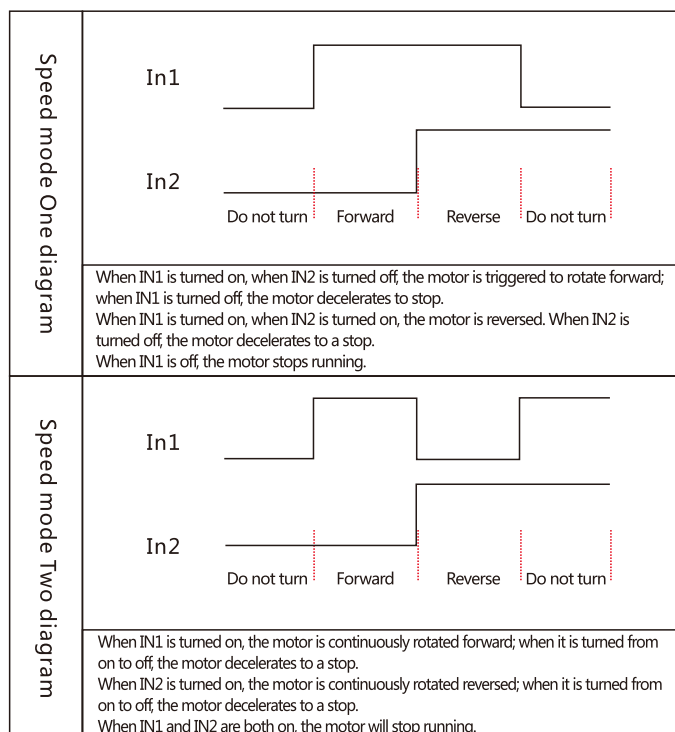

Dialing function description

SW9 OFF: IO control, ON: internal pulse automatic forward and reverse

SW10 OFF: Control mode 1, ON: Control mode 2

SW11: OFF: acceleration 1 (high acceleration), ON: acceleration 2 (low acceleration)

Rs485 bus type stepping driver 2LS860R

2LS860R high-performance 485 bus stepping drive, using 32-bit ARM processor, integrated intelligent motion controller function, built-in S-shaped acceleration and deceleration command, can independently set acceleration and deceleration. Real-time control of the drive and motor by running the Modbus protocol over the RS485 network. Debug interface: display parameter settings
 Maximum current: 7.2A
 Power supply: AC: 18V~80V or DC: 18V~110V
 Typical applications: assembly lines, lithium battery equipment, solar equipment, 3C electronic equipment, etc.



Drive function description

Drive function	Instructions
Slave address setting	The SW1-SW5 five dial switches are used to set a total of 32 slave addresses. Please select the corresponding settings against the drive panel.
Baud rate setting	The SW6-SW7 two dial switches are used to select a total of four baud rates. The master and slave must be set to the same baud rate. Please select the corresponding settings against the drive panel.
Terminal matching resistor	SW8 is used to select whether the 120 ohm terminating resistor is valid, OFF is invalid, and ON is valid.
Mode selection	SW9=OFF is the external mode, SW9=ON is the automatic operation mode
CN interface	5 single-ended input ports, 3 output ports, please see the table below for details.
Encoder interface	GND: Internal power supply output GND; +5V internal power supply output 5V, maximum output current 150mA. EA+ EA- Receive quadrature encoder Phase A signal. EB+ EB- Receive Quadrature Encoder Phase B signal.
Power and motor interface	AC: 18V~80V or DC: 18V~110V. A+, A-, B+, B- respectively connect the A and B phase windings of the two-phase motor
RJ45 interface	Network communication interface, also used to connect display debugging

Drive working status LED indication

LED Status	Drive status
● Long green light	Drive not enabled
●● Flashing green light	The drive is working properly
●● 1 green 1 red	Drive over current
●●● 1 green 2 red	Driver input power supply overvoltage
●●●● 1 green 3 red	Drive internal voltage error
●●●●● 1 green 4 red	Encoder out of tolerance alarm
●●●●●● 1 green 5 red	Encoder error
●●●●●●● 1 green 6 red	Parameter verification error
●●●●●●●● 1 green 7 red	Motor phase loss alarm

Pin definition

Pin	Name	Description
1	X0	Universal input port 0, default receiving 24V/0V level signal
2	X1	Universal input port 1, default receiving 24V/0V level signal
3	X2	Universal input port 2, default receiving 24V/0V level signal
4		
5		
6		
7	XCOM	Input power supply negative
8	Y0	General-purpose output port 0, optocoupler isolation, open collector
9	Y1	General-purpose output port 1, optocoupler isolation, open collector
10	Y2	General-purpose output port 2, optocoupler isolation, open collector
11	YCOM	Output power supply negative

Set from slave address

Slave address: In the same network, each slave has a unique address, on=0, off=1
 Slave address = SW1+SW2×2+SW3×4+SW4×8+SW5×16

Slave ID	Sw1	Sw2	Sw3	Sw4	Sw5
Default	on	on	on	on	on
1	off	on	on	on	on
2	on	off	on	on	on
.....
30	on	off	off	off	off
31	off	off	off	off	off

Baud rate

Master and slave must be set to the same baud rate

BDR	Sw6	Sw7
9600	on	on
19200	off	on
38400	on	off
115200	off	off

Our market



COMMITTED TO MACHINE INTELLIGENCE, FOCUS MOTOR CONTROL



BERGERDA Hangzhou Bergerda Automation technology co., LTD

Address: 4F, Building 8, No. 493, Linping Avenue, Economic and Technological Development Zone, Linping District, Hangzhou, Zhejiang, China

Sale : 0086-13968026835

Technical : 0086-571-88645851

Fax : 0086-571-89719501

Mail : market@bergerda.com

web : www.bergerda.com

Post Code : 310030